

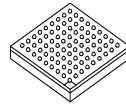

MCF5329

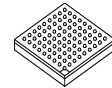

MAPBGA-256
17mm x 17mm



MAPBGA-196
15mm x 15mm

MCF532x ColdFire® Microprocessor Data Sheet

Features

- Version 3 ColdFire variable-length RISC processor core
- System debug support
- JTAG support for system level board testing
- On-chip memories
 - 16-Kbyte unified write-back cache
 - 32-Kbyte dual-ported SRAM on CPU internal bus, accessible by core and non-core bus masters (e.g., DMA, FEC, LCD controller, and USB host and OTG)
- Power management
- Liquid Crystal Display Controller (LCDC)
- Embedded Voice-over-IP (VoIP) system solution
- SDR/DDR SDRAM Controller
- Universal Serial Bus (USB) Host Controller
- Universal Serial Bus (USB) On-the-Go (OTG) controller
- Synchronous Serial Interface (SSI)
- Fast Ethernet Controller (FEC)
- Cryptography Hardware Accelerators
- FlexCAN Module
- Three Universal Asynchronous Receiver Transmitters (UARTs)
- I²C Module
- Queued Serial Peripheral Interface (QSPI)
- Pulse Width Modulation (PWM) module
- Real Time Clock
- Four 32-bit DMA Timers
- Software Watchdog Timer
- Four Periodic Interrupt Timers (PITs)
- Phase Locked Loop (PLL)
- Interrupt Controllers (x2)
- DMA Controller
- FlexBus (External Interface)
- Chip Configuration Module (CCM)
- Reset Controller
- General Purpose I/O interface

Table of Contents

1	MCF532x Family Comparison	3	5.7.2	DDR SDRAM AC Timing Characteristics	25
2	Ordering Information	4	5.8	General Purpose I/O Timing	28
3	Hardware Design Considerations	5	5.9	Reset and Configuration Override Timing	29
3.1	PLL Power Filtering	5	5.10	LCD Controller Timing Specifications	30
3.2	USB Power Filtering	5	5.11	USB On-The-Go	33
3.3	Supply Voltage Sequencing and Separation Cautions	5	5.12	ULPI Timing Specification	33
3.3.1	Power Up Sequence	5	5.13	SSI Timing Specifications	33
3.3.2	Power Down Sequence	6	5.14	I ² C Input/Output Timing Specifications	35
4	Pin Assignments and Reset States	6	5.15	Fast Ethernet AC Timing Specifications	37
4.1	Signal Multiplexing	6	5.15.1	MII Receive Signal Timing	37
4.2	Pinout—256 MAPBGA	14	5.15.2	MII Transmit Signal Timing	37
4.3	Pinout—196 MAPBGA	15	5.15.3	MII Async Inputs Signal Timing	38
5	Electrical Characteristics	15	5.15.4	MII Serial Management Channel Timing	38
5.1	Maximum Ratings	16	5.16	32-Bit Timer Module Timing Specifications	39
5.2	Thermal Characteristics	17	5.17	QSPI Electrical Specifications	39
5.3	ESD Protection	18	5.18	JTAG and Boundary Scan Timing	40
5.4	DC Electrical Specifications	18	5.19	Debug AC Timing Specifications	42
5.5	Oscillator and PLL Electrical Characteristics	19	6	Current Consumption	42
5.6	External Interface Timing Characteristics	20	7	Package Information	46
5.6.1	FlexBus	21	7.1	Package Dimensions—256 MAPBGA	46
5.7	SDRAM Bus	23	7.2	Package Dimensions—196 MAPBGA	47
5.7.1	SDR SDRAM AC Timing Characteristics	23	8	Revision History	48

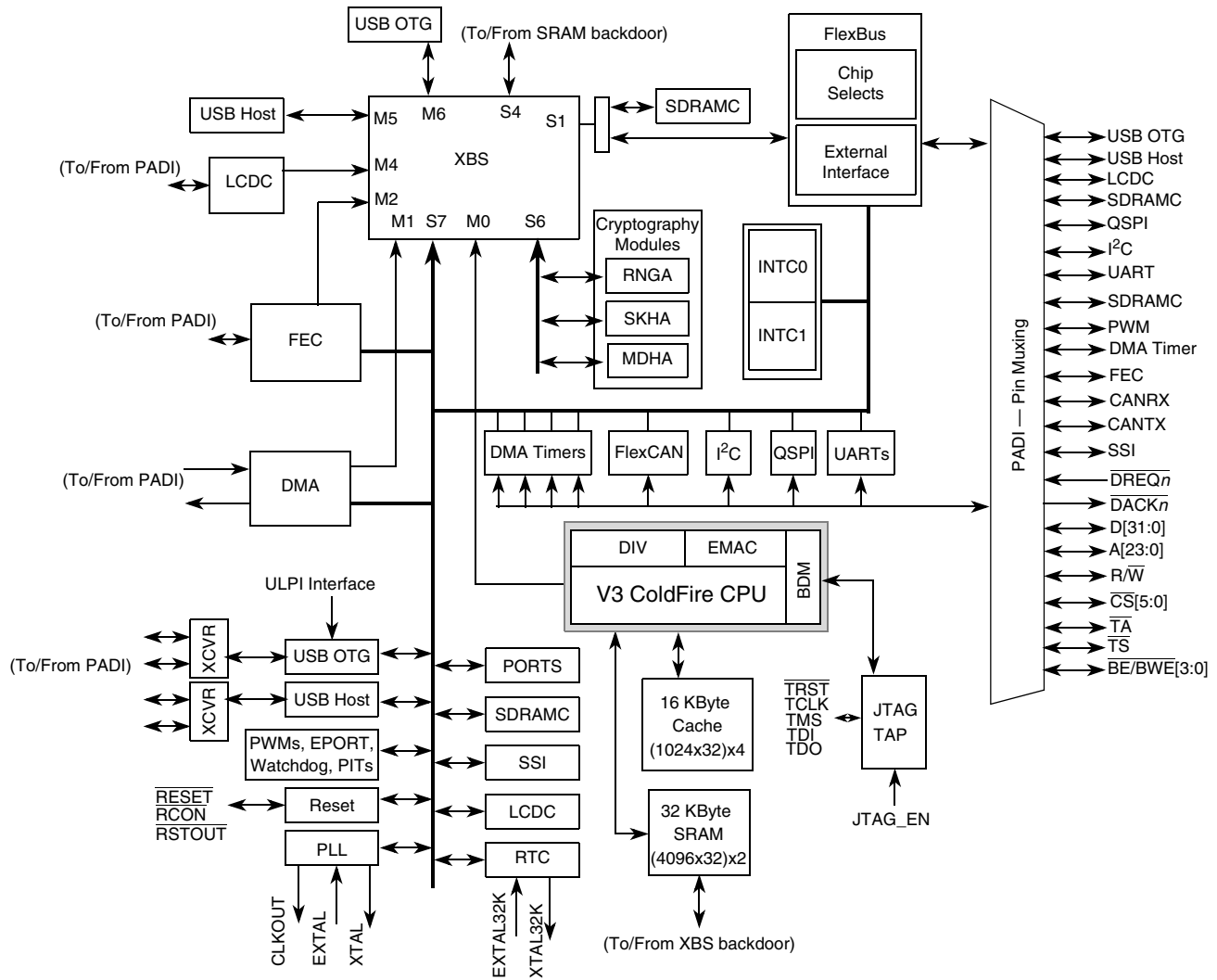

Figure 1. MCF5329 Block Diagram

1 MCF532x Family Comparison

The following table compares the various device derivatives available within the MCF532x family.

Table 1. MCF532x Family Configurations

Module	MCF5327	MCF5328	MCF53281	MCF5329
ColdFire Version 3 Core with EMAC (Enhanced Multiply-Accumulate Unit)	•	•	•	•
Core (System) Clock	up to 240 MHz			
Peripheral and External Bus Clock (Core clock ÷ 3)	up to 80 MHz			
Performance (Dhrystone/2.1 MIPS)	up to 211			
Unified Cache	16 Kbytes			
Static RAM (SRAM)	32 Kbytes			

Table 1. MCF532x Family Configurations (continued)

Module	MCF5327	MCF5328	MCF53281	MCF5329
LCD Controller	•	•	•	•
SDR/DDR SDRAM Controller	•	•	•	•
USB 2.0 Host	•	•	•	•
USB 2.0 On-the-Go	•	•	•	•
UTMI+ Low Pin Interface (ULPI)	—	•	•	•
Synchronous Serial Interface (SSI)	•	•	•	•
Fast Ethernet Controller (FEC)	—	•	•	•
Cryptography Hardware Accelerators	—	—	—	•
Embedded Voice-over-IP System Solution	—	—	•	—
FlexCAN 2.0B communication module	—	—	•	•
UARTs	3	3	3	3
I ² C	•	•	•	•
QSPI	•	•	•	•
PWM Module	•	•	•	•
Real Time Clock	•	•	•	•
32-bit DMA Timers	4	4	4	4
Watchdog Timer (WDT)	•	•	•	•
Periodic Interrupt Timers (PIT)	4	4	4	4
Edge Port Module (EPORT)	•	•	•	•
Interrupt Controllers (INTC)	2	2	2	2
16-channel Direct Memory Access (DMA)	•	•	•	•
FlexBus External Interface	•	•	•	•
General Purpose I/O Module (GPIO)	•	•	•	•
JTAG - IEEE [®] 1149.1 Test Access Port	•	•	•	•
Package	196 MAPBGA	256 MAPBGA	256 MAPBGA	256 MAPBGA

2 Ordering Information

Table 2. Orderable Part Numbers

Freescall Part Number	Description	Package	Speed	Temperature
MCF5327CVM240	MCF5327 RISC Microprocessor	196 MAPBGA	240 MHz	–40° to +85° C
MCF5328CVM240	MCF5328 RISC Microprocessor	256 MAPBGA	240 MHz	–40° to +85° C
MCF53281CVM240	MCF53281 RISC Microprocessor	256 MAPBGA	240 MHz	–40° to +85° C
MCF5329CVM240	MCF5329 RISC Microprocessor	256 MAPBGA	240 MHz	–40° to +85° C

3 Hardware Design Considerations

3.1 PLL Power Filtering

To further enhance noise isolation, an external filter is strongly recommended for PLL analog V_{DD} pins. The filter shown in Figure 2 should be connected between the board V_{DD} and the PLL V_{DD} pins. The resistor and capacitors should be placed as close to the dedicated PLL V_{DD} pin as possible.

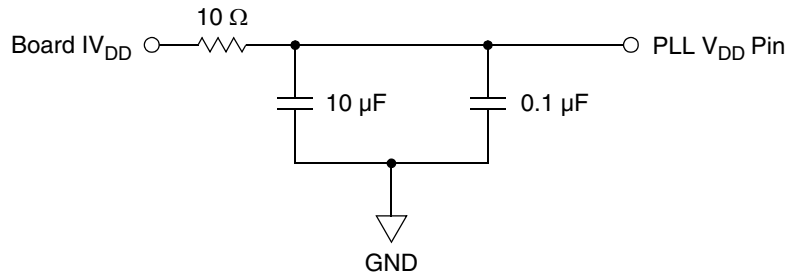

Figure 2. System PLL V_{DD} Power Filter

3.2 USB Power Filtering

To minimize noise, external filters are required for each of the USB power pins. The filter shown in Figure 3 should be connected between the board EV_{DD} or IV_{DD} and each of the USB V_{DD} pins. The resistor and capacitors should be placed as close to the dedicated USB V_{DD} pin as possible.

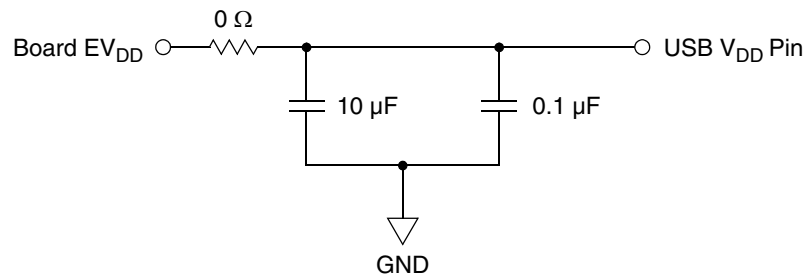

Figure 3. USB V_{DD} Power Filter

NOTE

In addition to the above filter circuitry, a 0.01 F capacitor is also recommended in parallel with those shown.

3.3 Supply Voltage Sequencing and Separation Cautions

The relationship between SDV_{DD} and EV_{DD} is non-critical during power-up and power-down sequences. SDV_{DD} (2.5V or 3.3V) and EV_{DD} are specified relative to IV_{DD} .

3.3.1 Power Up Sequence

If EV_{DD}/SDV_{DD} are powered up with IV_{DD} at 0 V, the sense circuits in the I/O pads cause all pad output drivers connected to the EV_{DD}/SDV_{DD} to be in a high impedance state. There is no limit on how long after EV_{DD}/SDV_{DD} powers up before IV_{DD} must powered up. IV_{DD} should not lead the EV_{DD} , SDV_{DD} , or PLL V_{DD} by more than 0.4 V during power ramp-up or there is

high current in the internal ESD protection diodes. The rise times on the power supplies should be slower than 500 us to avoid turning on the internal ESD protection clamp diodes.

3.3.2 Power Down Sequence

If $IV_{DD}/PLL_{V_{DD}}$ are powered down first, sense circuits in the I/O pads cause all output drivers to be in a high impedance state. There is no limit on how long after IV_{DD} and $PLL_{V_{DD}}$ power down before EV_{DD} or SDV_{DD} must power down. IV_{DD} should not lag EV_{DD} , SDV_{DD} , or $PLL_{V_{DD}}$ going low by more than 0.4 V during power down or there is undesired high current in the ESD protection diodes. There are no requirements for the fall times of the power supplies.

The recommended power down sequence is as follows:

1. Drop $IV_{DD}/PLL_{V_{DD}}$ to 0 V.
2. Drop EV_{DD}/SDV_{DD} supplies.

4 Pin Assignments and Reset States

4.1 Signal Multiplexing

The following table lists all the MCF532x pins grouped by function. The Dir column is the direction for the primary function of the pin only. Refer to [Section 7, “Package Information,”](#) for package diagrams. For a more detailed discussion of the MCF532x signals, consult the *MCF5329 Reference Manual (MCF5329RM)*.

NOTE

In this table and throughout this document, a single signal within a group is designated without square brackets (i.e., A23), while designations for multiple signals within a group use brackets (i.e., A[23:21]) and is meant to include all signals within the two bracketed numbers when these numbers are separated by a colon.

NOTE

The primary functionality of a pin is not necessarily its default functionality. Pins that are muxed with GPIO default to their GPIO functionality.

Table 3. MCF5327/8/9 Signal Information and Muxing

Signal Name	GPIO	Alternate 1	Alternate 2	Dir. ¹	Voltage Domain	MCF5327 196 MAPBGA	MCF5328 256 MAPBGA	MCF53281 MCF5329 256 MAPBGA
Reset								
$\overline{\text{RESET}}^2$	—	—	—	I	EVDD	J11	N15	N15
$\overline{\text{RSTOUT}}$	—	—	—	O	EVDD	P14	P14	P14
Clock								
EXTAL	—	—	—	I	EVDD	L14	P16	P16
XTAL ²	—	—	—	O	EVDD	K14	N16	N16
EXTAL32K	—	—	—	I	EVDD	M11	P13	P13
XTAL32K	—	—	—	O	EVDD	N11	R13	R13
FB_CLK	—	—	—	O	SDVDD	L1	T2	T2

Table 3. MCF5327/8/9 Signal Information and Muxing (continued)

Signal Name	GPIO	Alternate 1	Alternate 2	Dir. ¹	Voltage Domain	MCF5327 196 MAPBGA	MCF5328 256 MAPBGA	MCF53281 MCF5329 256 MAPBGA
Mode Selection								
$\overline{\text{RCON}}^2$	—	—	—	I	EVDD	M7	M8	M8
DRAMSEL	—	—	—	I	EVDD	G11	H12	H12
FlexBus								
A[23:22]	—	$\overline{\text{FB_CS}}[5:4]$	—	O	SDVDD	B11, C11	C13, D13	C13, D13
A[21:16]	—	—	—	O	SDVDD	B12, A12, D11, C12, B13, A13	E13, A14, B14, C14, A15, B15	E13, A14, B14, C14, A15, B15
A[15:14]	—	SD_BA[1:0] ³	—	O	SDVDD	A14, B14	D14, B16	D14, B16
A[13:11]	—	SD_A[13:11] ³	—	O	SDVDD	C13, C14, D12	C15, C16, D15	C15, C16, D15
A10	—	—	—	O	SDVDD	D13	D16	D16
A[9:0]	—	SD_A[9:0] ³	—	O	SDVDD	D14, E11–14, F11–F14, G14	E14–E16, F13–F16, G16–G14	E14–E16, F13–F16, G16–G14
D[31:16]	—	SD_D[31:16] ⁴	—	I/O	SDVDD	H3–H1, J4–J1, K1, L4, M2, M3, N1, N2, P1, P2, N3	M1–M4, N1–N4, T3, P4, R4, T4, N5, P5, R5, T5	M1–M4, N1–N4, T3, P4, R4, T4, N5, P5, R5, T5
D[15:1]	—	FB_D[31:17] ⁴	—	I/O	SDVDD	F4–F1, G5–G2, L5, N4, P4, M5, N5, P5, L6	J3–J1, K4–K1, L2, R6, N7, P7, R7, T7, P8, R8	J3–J1, K4–K1, L2, R6, N7, P7, R7, T7, P8, R8
D0 ²	—	FB_D[16] ⁴	—	I/O	SDVDD	M6	T8	T8
$\overline{\text{BE}}/\overline{\text{BWE}}[3:0]$	PBE[3:0]	$\overline{\text{SD_DQM}}[3:0]^3$	—	O	SDVDD	H4, P3, G1, M4	L4, P6, L3, N6	L4, P6, L3, N6
$\overline{\text{OE}}$	PBUSCTL3	—	—	O	SDVDD	P6	R9	R9
$\overline{\text{TA}}^2$	PBUSCTL2	—	—	I	SDVDD	G13	G13	G13
R/ $\overline{\text{W}}$	PBUSCTL1	—	—	O	SDVDD	N6	N8	N8
$\overline{\text{TS}}$	PBUSCTL0	$\overline{\text{DACK0}}$	—	O	SDVDD	D2	H4	H4
Chip Selects								
$\overline{\text{FB_CS}}[5:4]$	PCS[5:4]	—	—	O	SDVDD	—	B13, A13	B13, A13
$\overline{\text{FB_CS}}[3:1]$	PCS[3:1]	—	—	O	SDVDD	A11, D10, C10	A12, B12, C12	A12, B12, C12
$\overline{\text{FB_CS0}}$	—	—	—	O	SDVDD	B10	D12	D12

Table 3. MCF5327/8/9 Signal Information and Muxing (continued)

Signal Name	GPIO	Alternate 1	Alternate 2	Dir. ¹	Voltage Domain	MCF5327 196 MAPBGA	MCF5328 256 MAPBGA	MCF53281 MCF5329 256 MAPBGA
SDRAM Controller								
SD_A10	—	—	—	O	SDVDD	L2	P2	P2
SD_CKE	—	—	—	O	SDVDD	E1	H2	H2
SD_CLK	—	—	—	O	SDVDD	K3	R1	R1
$\overline{\text{SD_CLK}}$	—	—	—	O	SDVDD	K2	R2	R2
$\overline{\text{SD_CS1}}$	—	—	—	O	SDVDD	—	J4	J4
$\overline{\text{SD_CS0}}$	—	—	—	O	SDVDD	E2	H1	H1
SD_DQS3	—	—	—	O	SDVDD	H5	L1	L1
SD_DQS2	—	—	—	O	SDVDD	K6	T6	T6
$\overline{\text{SD_SCAS}}$	—	—	—	O	SDVDD	L3	P3	P3
$\overline{\text{SD_SRAS}}$	—	—	—	O	SDVDD	M1	R3	R3
SD_SDR_DQS	—	—	—	O	SDVDD	K4	P1	P1
$\overline{\text{SD_WE}}$	—	—	—	O	SDVDD	D1	H3	H3
External Interrupts Port⁵								
$\overline{\text{IRQ7}}^2$	PIRQ7 ²	—	—	I	EVDD	J13	J13	J13
$\overline{\text{IRQ6}}^2$	PIRQ6 ²	USBHOST_ VBUS_EN	—	I	EVDD	—	J14	J14
$\overline{\text{IRQ5}}^2$	PIRQ5 ²	USBHOST_ VBUS_OC	—	I	EVDD	—	J15	J15
$\overline{\text{IRQ4}}^2$	PIRQ4 ²	SSI_MCLK	—	I	EVDD	L13	J16	J16
$\overline{\text{IRQ3}}^2$	PIRQ3 ²	—	—	I	EVDD	M14	K14	K14
$\overline{\text{IRQ2}}^2$	PIRQ2 ²	USB_CLKIN	—	I	EVDD	M13	K15	K15
$\overline{\text{IRQ1}}^2$	PIRQ1 ²	$\overline{\text{DREQ1}}^2$	SSI_CLKIN	I	EVDD	N13	K16	K16
FEC								
FEC_MDC	PFECI2C3	I2C_SCL ²	—	O	EVDD	—	C1	C1
FEC_MDIO	PFECI2C2	I2C_SDA ²	—	I/O	EVDD	—	C2	C2
FEC_TXCLK	PFECH7	—	—	I	EVDD	—	A2	A2
FEC_TXEN	PFECH6	—	—	O	EVDD	—	B2	B2
FEC_TXD0	PFECH5	ULPI_DATA0	—	O	EVDD	—	E4	E4
FEC_COL	PFECH4	ULPI_CLK	—	I	EVDD	—	A8	A8
FEC_RXCLK	PFECH3	ULPI_NXT	—	I	EVDD	—	C8	C8
FEC_RXDV	PFECH2	ULPI_STP	—	I	EVDD	—	D8	D8
FEC_RXD0	PFECH1	ULPI_DATA4	—	I	EVDD	—	C6	C6

Table 3. MCF5327/8/9 Signal Information and Muxing (continued)

Signal Name	GPIO	Alternate 1	Alternate 2	Dir. ¹	Voltage Domain	MCF5327 196 MAPBGA	MCF5328 256 MAPBGA	MCF53281 MCF5329 256 MAPBGA
FEC_CRCS	PFECH0	ULPI_DIR	—	I	EVDD	—	B8	B8
FEC_TXD[3:1]	PFECL[7:5]	ULPI_DATA[3:1]	—	O	EVDD	—	D3–D1	D3–D1
FEC_TXER	PFECL4	—	—	O	EVDD	—	B1	B1
FEC_RXD[3:1]	PFECL[3:1]	ULPI_DATA[7:5]	—	I	EVDD	—	E7, A6, B6	E7, A6, B6
FEC_RXER	PFECL0	—	—	I	EVDD	—	D4	D4
LCD Controller								
LCD_D17	PLCDDH1	CANTX	—	O	EVDD	—	—	C9
LCD_D16	PLCDDH0	CANRX	—	O	EVDD	—	—	D9
LCD_D17	PLCDDH1	—	—	O	EVDD	A6	C9	—
LCD_D16	PLCDDH0	—	—	O	EVDD	B6	D9	—
LCD_D15	PLCDDM7	—	—	O	EVDD	C6	A7	A7
LCD_D14	PLCDDM6	—	—	O	EVDD	D6	B7	B7
LCD_D13	PLCDDM5	—	—	O	EVDD	A5	C7	C7
LCD_D12	PLCDDM4	—	—	O	EVDD	B5	D7	D7
LCD_D[11:8]	PLCDDM[3:0]	—	—	O	EVDD	C5, D5, A4, B4	D6, E6, A5, B5	D6, E6, A5, B5
LCD_D7	PLCDDL7	—	—	O	EVDD	C4	C5	C5
LCD_D6	PLCDDL6	—	—	O	EVDD	B3	D5	D5
LCD_D5	PLCDDL5	—	—	O	EVDD	A3	A4	A4
LCD_D4	PLCDDL4	—	—	O	EVDD	A2	A3	A3
LCD_D[3:0]	PLCDDL[3:0]	—	—	O	EVDD	D4, C3, D3, B2	B4, C4, B3, C3	B4, C4, B3, C3
LCD_ACD/ LCD_OE	PLCDCTLH0	—	—	O	EVDD	D7	B9	B9
LCD_CLS	PLCDCTLL7	—	—	O	EVDD	C7	A9	A9
LCD_CONTRAST	PLCDCTLL6	—	—	O	EVDD	B7	D10	D10
LCD_FLM/ LCD_VSYNC	PLCDCTLL5	—	—	O	EVDD	A7	C10	C10
LCD_LP/ LCD_HSYNC	PLCDCTLL4	—	—	O	EVDD	A8	B10	B10
LCD_LSCLK	PLCDCTLL3	—	—	O	EVDD	B8	A10	A10
LCD_PS	PLCDCTLL2	—	—	O	EVDD	C8	A11	A11
LCD_REV	PLCDCTLL1	—	—	O	EVDD	D8	B11	B11
LCD_SPL_SPR	PLCDCTLL0	—	—	O	EVDD	B9	C11	C11

Table 3. MCF5327/8/9 Signal Information and Muxing (continued)

Signal Name	GPIO	Alternate 1	Alternate 2	Dir. ¹	Voltage Domain	MCF5327 196 MAPBGA	MCF5328 256 MAPBGA	MCF53281 MCF5329 256 MAPBGA
USB Host & USB On-the-Go								
USBOTG_M	—	—	—	I/O	USB VDD	G12	L15	L15
USBOTG_P	—	—	—	I/O	USB VDD	H13	L16	L16
USBHOST_M	—	—	—	I/O	USB VDD	K13	M15	M15
USBHOST_P	—	—	—	I/O	USB VDD	J12	M16	M16
FlexCAN (MCF53281 & MCF5329 only)								
CANRX and CANTX do not have dedicated bond pads. Please refer to the following pins for muxing: I2C_SDA, SSI_RXD, or LCD_D16 for CANRX and I2C_SCL, SSI_TXD, or LCD_D17 for CANTX.								
PWM								
PWM7	PPWM7	—	—	I/O	EVDD	—	H13	H13
PWM5	PPWM5	—	—	I/O	EVDD	—	H14	H14
PWM3	PPWM3	DT3OUT	DT3IN	I/O	EVDD	H14	H15	H15
PWM1	PPWM1	DT2OUT	DT2IN	I/O	EVDD	J14	H16	H16
SSI								
SSI_MCLK	PSSI4	—	—	I/O	EVDD	—	G4	G4
SSI_BCLK	PSSI3	$\overline{U2CTS}$	PWM7	I/O	EVDD	—	F4	F4
SSI_FS	PSSI2	$\overline{U2RTS}$	PWM5	I/O	EVDD	—	G3	G3
SSI_RXD ²	PSSI1	U2RXD	CANRX	I	EVDD	—	—	G2
SSI_TXD ²	PSSI0	U2TXD	CANTX	O	EVDD	—	—	G1
SSI_RXD ²	PSSI1	U2RXD	—	I	EVDD	—	G2	—
SSI_TXD ²	PSSI0	U2TXD	—	O	EVDD	—	G1	—
I²C								
I2C_SCL ²	PFECI2C1	CANTX	U2TXD	I/O	EVDD	—	—	F3
I2C_SDA ²	PFECI2C0	CANRX	U2RXD	I/O	EVDD	—	—	F2
I2C_SCL ²	PFECI2C1	—	U2TXD	I/O	EVDD	E3	F3	—
I2C_SDA ²	PFECI2C0	—	U2RXD	I/O	EVDD	E4	F2	—
DMA								
$\overline{DACK}[1:0]$ and $\overline{DREQ}[1:0]$ do not have dedicated bond pads. Please refer to the following pins for muxing: \overline{TS} for $\overline{DACK0}$, DT0IN for $\overline{DREQ0}$, DT1IN for $\overline{DACK1}$, and $\overline{IRQ1}$ for $\overline{DREQ1}$.								

Table 3. MCF5327/8/9 Signal Information and Muxing (continued)

Signal Name	GPIO	Alternate 1	Alternate 2	Dir. ¹	Voltage Domain	MCF5327 196 MAPBGA	MCF5328 256 MAPBGA	MCF53281 MCF5329 256 MAPBGA
QSPI								
QSPI_CS2	PQSPI5	$\overline{U2RTS}$	—	O	EVDD	P10	T12	T12
QSPI_CS1	PQSPI4	PWM7	USBOTG_ PU_EN	O	EVDD	L11	T13	T13
QSPI_CS0	PQSPI3	PWM5	—	O	EVDD	—	P11	P11
QSPI_CLK	PQSPI2	I2C_SCL ²	—	O	EVDD	N10	R12	R12
QSPI_DIN	PQSPI1	$\overline{U2CTS}$	—	I	EVDD	L10	N12	N12
QSPI_DOUT	PQSPI0	I2C_SDA	—	O	EVDD	M10	P12	P12
UARTs								
$\overline{U1CTS}$	PUARTL7	SSI_BCLK	—	I	EVDD	C9	D11	D11
$\overline{U1RTS}$	PUARTL6	SSI_FS	—	O	EVDD	D9	E10	E10
U1TXD	PUARTL5	SSI_TXD ²	—	O	EVDD	A9	E11	E11
U1RXD	PUARTL4	SSI_RXD ²	—	I	EVDD	A10	E12	E12
$\overline{U0CTS}$	PUARTL3	—	—	I	EVDD	P13	R15	R15
$\overline{U0RTS}$	PUARTL2	—	—	O	EVDD	N12	T15	T15
U0TXD	PUARTL1	—	—	O	EVDD	P12	T14	T14
U0RXD	PUARTL0	—	—	I	EVDD	P11	R14	R14
Note: The UART2 signals are multiplexed on the QSPI, SSI, DMA Timers, and I2C pins.								
DMA Timers								
DT3IN	PTIMER3	DT3OUT	U2RXD	I	EVDD	C1	F1	F1
DT2IN	PTIMER2	DT2OUT	U2TXD	I	EVDD	B1	E1	E1
DT1IN	PTIMER1	DT1OUT	$\overline{DACK1}$	I	EVDD	A1	E2	E2
DT0IN	PTIMER0	DT0OUT	$\overline{DREQ0}$ ²	I	EVDD	C2	E3	E3
BDM/JTAG⁶								
JTAG_EN ⁷	—	—	—	I	EVDD	L12	M13	M13
DSCLK	—	\overline{TRST} ²	—	I	EVDD	N14	P15	P15
PSTCLK	—	TCLK ²	—	O	EVDD	L7	T9	T9
\overline{BKPT}	—	TMS ²	—	I	EVDD	M12	R16	R16
DSI	—	TDI ²	—	I	EVDD	K12	N14	N14
DSO	—	TDO	—	O	EVDD	N9	N11	N11
DDATA[3:0]	—	—	—	O	EVDD	N7, P7, L8, M8	N9, P9, N10, P10	N9, P9, N10, P10

Table 3. MCF5327/8/9 Signal Information and Muxing (continued)

Signal Name	GPIO	Alternate 1	Alternate 2	Dir. ¹	Voltage Domain	MCF5327 196 MAPBGA	MCF5328 256 MAPBGA	MCF53281 MCF5329 256 MAPBGA
PST[3:0]	—	—	—	O	EVDD	N8, P8, L9, M9	R10, T10, R11, T11	R10, T10, R11, T11
Test								
TEST ⁷	—	—	—	I	EVDD	E10	A16	A16
PLL_TEST ⁸	—	—	—	I	EVDD	—	N13	N13
Power Supplies								
EVDD	—	—	—	—	—	E6, E7, F5–F7, H9, J8, J9, K8, K9, K11	E8, F5–F8, G5, G6, H5, H6, J11, K11, K12, L9–L11, M9, M10	E8, F5–F8, G5, G6, H5, H6, J11, K11, K12, L9–L11, M9, M10
IVDD	—	—	—	—	—	E5, K5, K10, J10	E5, G12, M5, M11, M12	E5, G12, M5, M11, M12
PLL_VDD	—	—	—	—	—	H10	J12	J12
SD_VDD	—	—	—	—	—	E8, E9, F8–F10, J5–J7, K7	E9, F9–F11, G11, H11, J5, J6, K5, K6, L5–L8, M6, M7	E9, F9–F11, G11, H11, J5, J6, K5, K6, L5–L8, M6, M7
USB_VDD	—	—	—	—	—	G10	L14	L14
VSS	—	—	—	—	—	G6–G9, H6–H8, P9	G7–G10, H7–H10, J7–10, K7–K10, L12, L13	G7–G10, H7–H10, J7–10, K7–K10, L12, L13
PLL_VSS	—	—	—	—	—	H11	K13	K13
USB_VSS	—	—	—	—	—	H12	M14	M14

¹ Refers to pin's primary function.

² Pull-up enabled internally on this signal for this mode.

³ The SDRAM functions of these signals are not programmable by the user. They are dynamically switched by the processor when accessing SDRAM memory space and are included here for completeness.

⁴ Primary functionality selected by asserting the DRAMSEL signal (SDR mode). Alternate functionality selected by negating the DRAMSEL signal (DDR mode). The GPIO module is not responsible for assigning these pins.

⁵ GPIO functionality is determined by the edge port module. The GPIO module is only responsible for assigning the alternate functions.

⁶ If JTAG_EN is asserted, these pins default to Alternate 1 (JTAG) functionality. The GPIO module is not responsible for assigning these pins.

⁷ Pull-down enabled internally on this signal for this mode.

⁸ Must be left floating for proper operation of the PLL.

NOTE

4.2 Pinout—256 MAPBGA

Figure 4 shows a pinout of the MCF5328CVM240, MCF53281CVM240, and MCF5329CVM240 devices.

NOTE

The pin at location N13 (PLL_TEST) must be left floating or improper operation of the PLL module occurs.

	1	2	3	4	5	6	7	8	9	10	11	12	13	14	15	16	
A	NC	FEC_TXCLK	LCD_D4	LCD_D5	LCD_D9	FEC_RXD2	LCD_D15	FEC_COL	LCD_CLS	LCD_LSCLK	LCD_PS	FB_CS3	FB_CS4	A20	A17	TEST	A
B	FEC_TXER	FEC_TXEN	LCD_D1	LCD_D3	LCD_D8	FEC_RXD1	LCD_D14	FEC_CRS	LCD_ACD/OE	LCD_LP/HSYNC	LCD_REV	FB_CS2	FB_CS5	A19	A16	A14	B
C	FEC_MDC	FEC_MDIO	LCD_D0	LCD_D2	LCD_D7	FEC_RXD0	LCD_D13	FEC_RXCLK	LCD_D17	LCD_FLM/VSYNC	LCD_SPL_SPR	FB_CS1	A23	A18	A13	A12	C
D	FEC_TXD1	FEC_TXD2	FEC_TXD3	FEC_RXER	LCD_D6	LCD_D11	LCD_D12	FEC_RXDV	LCD_D16	LCD_CON TRAST	U1CTS	FB_CS0	A22	A15	A11	A10	D
E	DT2IN	DT1IN	DT0IN	FEC_TXD0	IVDD	LCD_D10	FEC_RXD3	EVDD	SD_VDD	U1RTS	U1TXD	U1RXD	A21	A9	A8	A7	E
F	DT3IN	I2C_SDA	I2C_SCL	SSI_BCLK	EVDD	EVDD	EVDD	EVDD	SD_VDD	SD_VDD	SD_VDD	NC	A6	A5	A4	A3	F
G	SSI_TXD	SSI_RXD	SSI_FS	SSI_MCLK	EVDD	EVDD	VSS	VSS	VSS	VSS	SD_VDD	IVDD	TA	A0	A1	A2	G
H	SD_CS0	SD_CKE	SD_WE	TS	EVDD	EVDD	VSS	VSS	VSS	VSS	SD_VDD	DRAM SEL	PWM7	PWM5	PWM3	PWM1	H
J	D13	D14	D15	SD_CS1	SD_VDD	SD_VDD	VSS	VSS	VSS	VSS	EVDD	PLL_VDD	IRQ7	IRQ6	IRQ5	IRQ4	J
K	D9	D10	D11	D12	SD_VDD	SD_VDD	VSS	VSS	VSS	VSS	EVDD	EVDD	PLL_VSS	IRQ3	IRQ2	IRQ1	K
L	SD_DQS3	D8	BE/BWE1	BE/BWE3	SD_VDD	SD_VDD	SD_VDD	SD_VDD	EVDD	EVDD	EVDD	VSS	USB_VSS	USBOTG_VDD	USB_OTG_M	USB_OTG_P	L
M	D31	D30	D29	D28	IVDD	SD_VDD	SD_VDD	RCON	EVDD	EVDD	IVDD	IVDD	JTAG_EN	USBHOST_VSS	USB_HOST_M	USB_HOST_P	M
N	D27	D26	D25	D24	D19	BE/BWE0	D6	R/W	DDATA3	DDATA1	TDO/DSO	QSPI_DIN	PLL_TEST	TDI/DSI	RESET	XTAL	N
P	SD_DR_DQS	SD_A10	SD_CAS	D22	D18	BE/BWE2	D5	D2	DDATA2	DDATA0	QSPI_CS0	QSPI_DOUT	EXTAL_32K	RSTOUT	TRST/DSCLK	EXTAL	P
R	SD_CLK	SD_CLK	SD_RAS	D21	D17	D7	D4	D1	OE	PST3	PST1	QSPI_CLK	XTAL_32K	U0RXD	U0CTS	TMS/BKPT	R
T	NC	FB_CLK	D23	D20	D16	SD_DQS2	D3	D0	TCLK/PSTCLK	PST2	PST0	QSPI_CS2	QSPI_CS1	U0TXD	U0RTS	NC	T
	1	2	3	4	5	6	7	8	9	10	11	12	13	14	15	16	

Figure 4. MCF5328CVM240, MCF53281CVM240, and MCF5329CVM240 Pinout Top View (256 MAPBGA)

4.3 Pinout—196 MAPBGA

The pinout for the MCF5327CVM240 package is shown below.

	1	2	3	4	5	6	7	8	9	10	11	12	13	14	
A	DT1IN	LCD_D4	LCD_D5	LCD_D9	LCD_D13	LCD_D17	LCD_FLM/ VSYNC	LCD_LP/ HSYNC	U1TXD	U1RXD	$\overline{\text{FB_CS3}}$	A20	A16	A15	A
B	D2TIN	LCD_D0	LCD_D6	LCD_D8	LCD_D12	LCD_D16	LCD_CON TRAST	LCD_LSCLK	LCD_SPL_SPR	$\overline{\text{FB_CS0}}$	A23	A21	A17	A14	B
C	DT3IN	DT0IN	LCD_D2	LCD_D7	LCD_D11	LCD_D15	LCD_CLS	LCD_PS	$\overline{\text{U1CTS}}$	$\overline{\text{FB_CS1}}$	A22	A18	A13	A12	C
D	$\overline{\text{SD_WE}}$	$\overline{\text{TS}}$	LCD_D1	LCD_D3	LCD_D10	LCD_D14	LCD_ACD/OE	LCD_REV	$\overline{\text{U1RTS}}$	$\overline{\text{FB_CS2}}$	A19	A11	A10	A9	D
E	SD_CKE	$\overline{\text{SD_CS0}}$	I2C_SCL	I2C_SDA	IVDD	EVDD	EVDD	SD_VDD	SD_VDD	TEST	A8	A7	A6	A5	E
F	D12	D13	D14	D15	EVDD	EVDD	EVDD	SD_VDD	SD_VDD	SD_VDD	A4	A3	A2	A1	F
G	$\overline{\text{BE/}}/$ BWE1	D8	D9	D10	D11	VSS	VSS	VSS	VSS	USB OTG_VDD	DRAM SEL	USB OTG_M	$\overline{\text{TA}}$	A0	G
H	D29	D30	D31	$\overline{\text{BE/}}/$ BWE3	SD_DQS3	VSS	VSS	VSS	EVDD	PLL_VDD	PLL_VSS	USBHOST_VSS	USB OTG_P	PWM3	H
J	D25	D26	D27	D28	SD_VDD	SD_VDD	SD_VDD	EVDD	EVDD	IVDD	$\overline{\text{RESET}}$	USB HOST_P	$\overline{\text{IRQ7}}$	PWM1	J
K	D24	$\overline{\text{SD_CLK}}$	SD_CLK	SD_DR_DQS	IVDD	SD_DQS2	SD_VDD	EVDD	EVDD	IVDD	EVDD	TDI/DSI	USB HOST_M	XTAL	K
L	FB_CLK	SD_A10	$\overline{\text{SD_CAS}}$	D23	D7	D1	TCLK/ PSTCLK	DDATA1	PST1	QSPI_DIN	QSPI_CS1	JTAG_EN	$\overline{\text{IRQ4}}$	EXTAL	L
M	$\overline{\text{SD_RAS}}$	D22	D21	$\overline{\text{BE/}}/$ BWE0	D4	D0	$\overline{\text{RCON}}$	DDATA0	PST0	QSPI_DOUT	EXTAL 32K	TMS/ BKPT	$\overline{\text{IRQ2}}$	$\overline{\text{IRQ3}}$	M
N	D20	D19	D16	D6	D3	R/W	DDATA3	PST3	TDO/ DSO	QSPI_CLK	XTAL 32K	$\overline{\text{U0RTS}}$	$\overline{\text{IRQ1}}$	$\overline{\text{TRST/}}/$ DSCLK	N
P	D18	D17	$\overline{\text{BE/}}/$ BWE2	D5	D2	$\overline{\text{OE}}$	DDATA2	PST2	VSS	QSPI_CS2	U0RXD	U0TXD	$\overline{\text{U0CTS}}$	$\overline{\text{RSTOUT}}$	P
	1	2	3	4	5	6	7	8	9	10	11	12	13	14	

Figure 5. MCF5327CVM240 Pinout Top View (196 MAPBGA)

5 Electrical Characteristics

This document contains electrical specification tables and reference timing diagrams for the MCF5329 microcontroller unit. This section contains detailed information on power considerations, DC/AC electrical characteristics, and AC timing specifications of MCF5329.

The electrical specifications are preliminary and are from previous designs or design simulations. These specifications may not be fully tested or guaranteed at this early stage of the product life cycle. However, for production silicon, these specifications will be met. Finalized specifications will be published after complete characterization and device qualifications have been completed.

NOTE

The parameters specified in this MCU document supersede any values found in the module specifications.

5.1 Maximum Ratings

Table 4. Absolute Maximum Ratings^{1, 2}

Rating	Symbol	Value	Unit
Core Supply Voltage	IV_{DD}	- 0.5 to +2.0	V
CMOS Pad Supply Voltage	EV_{DD}	- 0.3 to +4.0	V
DDR/Memory Pad Supply Voltage	SDV_{DD}	- 0.3 to +4.0	V
PLL Supply Voltage	$PLLV_{DD}$	- 0.3 to +2.0	V
Digital Input Voltage ³	V_{IN}	- 0.3 to +3.6	V
Instantaneous Maximum Current Single pin limit (applies to all pins) ^{3, 4, 5}	I_D	25	mA
Operating Temperature Range (Packaged)	T_A ($T_L - T_H$)	- 40 to +85	°C
Storage Temperature Range	T_{stg}	- 55 to +150	°C

¹ Functional operating conditions are given in [Section 5.4, “DC Electrical Specifications.”](#) Absolute maximum ratings are stress ratings only, and functional operation at the maxima is not guaranteed. Continued operation at these levels may affect device reliability or cause permanent damage to the device.

² This device contains circuitry protecting against damage due to high static voltage or electrical fields; however, it is advised that normal precautions be taken to avoid application of any voltages higher than maximum-rated voltages to this high-impedance circuit. Reliability of operation is enhanced if unused inputs are tied to an appropriate logic voltage level (V_{SS} or EV_{DD}).

³ Input must be current limited to the value specified. To determine the value of the required current-limiting resistor, calculate resistance values for positive and negative clamp voltages, and then use the larger of the two values.

⁴ All functional non-supply pins are internally clamped to V_{SS} and EV_{DD} .

⁵ Power supply must maintain regulation within operating EV_{DD} range during instantaneous and operating maximum current conditions. If positive injection current ($V_{in} > EV_{DD}$) is greater than I_D , the injection current may flow out of EV_{DD} and could result in external power supply going out of regulation. Ensure external EV_{DD} load shunts current greater than maximum injection current. This is the greatest risk when the MCU is not consuming power (ex; no clock). Power supply must maintain regulation within operating EV_{DD} range during instantaneous and operating maximum current conditions.

5.2 Thermal Characteristics

Table 5. Thermal Characteristics

Characteristic		Symbol	256MBGA	196MBGA	Unit
Junction to ambient, natural convection	Four layer board (2s2p)	θ_{JMA}	37 ^{1,2}	42 ^{1,2}	°C/W
Junction to ambient (@200 ft/min)	Four layer board (2s2p)	θ_{JMA}	34 ^{1,2}	38 ^{1,2}	°C/W
Junction to board	—	θ_{JB}	27 ³	32 ³	°C/W
Junction to case	—	θ_{JC}	16 ⁴	19 ⁴	°C/W
Junction to top of package	—	Ψ_{jt}	4 ^{1,5}	5 ^{1,5}	°C/W
Maximum operating junction temperature	—	T_j	105	105	°C

¹ θ_{JMA} and Ψ_{jt} parameters are simulated in conformance with EIA/JESD Standard 51-2 for natural convection. Freescale recommends the use of θ_{JmA} and power dissipation specifications in the system design to prevent device junction temperatures from exceeding the rated specification. System designers should be aware that device junction temperatures can be significantly influenced by board layout and surrounding devices. Conformance to the device junction temperature specification can be verified by physical measurement in the customer's system using the Ψ_{jt} parameter, the device power dissipation, and the method described in EIA/JESD Standard 51-2.

² Per JEDEC JESD51-6 with the board horizontal.

³ Thermal resistance between the die and the printed circuit board in conformance with JEDEC JESD51-8. Board temperature is measured on the top surface of the board near the package.

⁴ Thermal resistance between the die and the case top surface as measured by the cold plate method (MIL SPEC-883 Method 1012.1).

⁵ Thermal characterization parameter indicating the temperature difference between package top and the junction temperature per JEDEC JESD51-2. When Greek letters are not available, the thermal characterization parameter is written in conformance with Psi-JT.

The average chip-junction temperature (T_j) in °C can be obtained from:

$$T_j = T_A + (P_D \times \theta_{JMA}) \quad \text{Eqn. 1}$$

Where:

T_A	= Ambient Temperature, °C
θ_{JMA}	= Package Thermal Resistance, Junction-to-Ambient, °C/W
P_D	= $P_{INT} + P_{I/O}$
P_{INT}	= $I_{DD} \times IV_{DD}$, Watts - Chip Internal Power
$P_{I/O}$	= Power Dissipation on Input and Output Pins - User Determined

For most applications $P_{I/O} < P_{INT}$ and can be ignored. An approximate relationship between P_D and T_j (if $P_{I/O}$ is neglected) is:

$$P_D = \frac{K}{(T_j + 273^\circ C)} \quad \text{Eqn. 2}$$

Solving equations 1 and 2 for K gives:

$$K = P_D \times (T_A \times 273^\circ C) + \theta_{JMA} \times P_D^2 \quad \text{Eqn. 3}$$

Electrical Characteristics

where K is a constant pertaining to the particular part. K can be determined from Equation 3 by measuring P_D (at equilibrium) for a known T_A . Using this value of K, the values of P_D and T_J can be obtained by solving Equation 1 and Equation 2 iteratively for any value of T_A .

5.3 ESD Protection

Table 6. ESD Protection Characteristics^{1, 2}

Characteristics	Symbol	Value	Units
ESD Target for Human Body Model	HBM	2000	V

¹ All ESD testing is in conformity with CDF-AEC-Q100 Stress Test Qualification for Automotive Grade Integrated Circuits.

² A device is defined as a failure if after exposure to ESD pulses the device no longer meets the device specification requirements. Complete DC parametric and functional testing is performed per applicable device specification at room temperature followed by hot temperature, unless specified otherwise in the device specification.

5.4 DC Electrical Specifications

Table 7. DC Electrical Specifications

Characteristic	Symbol	Min	Max	Unit
Core Supply Voltage	IV_{DD}	1.4	1.6	V
PLL Supply Voltage	$PLL_{V_{DD}}$	1.4	1.6	V
CMOS Pad Supply Voltage	EV_{DD}	3.0	3.6	V
SDRAM and FlexBus Supply Voltage Mobile DDR/Bus Pad Supply Voltage (nominal 1.8V) DDR/Bus Pad Supply Voltage (nominal 2.5V) SDR/Bus Pad Supply Voltage (nominal 3.3V)	SDV_{DD}	1.70 2.25 3.0	1.95 2.75 3.6	V
USB Supply Voltage	$USB_{V_{DD}}$	3.0	3.6	V
CMOS Input High Voltage	EV_{IH}	2	$EV_{DD} + 0.3$	V
CMOS Input Low Voltage	EV_{IL}	$V_{SS} - 0.3$	0.8	V
CMOS Output High Voltage $I_{OH} = -5.0$ mA	EV_{OH}	$EV_{DD} - 0.4$	—	V
CMOS Output Low Voltage $I_{OL} = 5.0$ mA	EV_{OL}	—	0.4	V
SDRAM and FlexBus Input High Voltage Mobile DDR/Bus Input High Voltage (nominal 1.8V) DDR/Bus Pad Supply Voltage (nominal 2.5V) SDR/Bus Pad Supply Voltage (nominal 3.3V)	SDV_{IH}	1.35 1.7 2	$SDV_{DD} + 0.3$ $SDV_{DD} + 0.3$ $SDV_{DD} + 0.3$	V
SDRAM and FlexBus Input Low Voltage Mobile DDR/Bus Input High Voltage (nominal 1.8V) DDR/Bus Pad Supply Voltage (nominal 2.5V) SDR/Bus Pad Supply Voltage (nominal 3.3V)	SDV_{IL}	$V_{SS} - 0.3$ $V_{SS} - 0.3$ $V_{SS} - 0.3$	0.45 0.8 0.8	V

Table 7. DC Electrical Specifications (continued)

Characteristic	Symbol	Min	Max	Unit
SDRAM and FlexBus Output High Voltage Mobile DDR/Bus Input High Voltage (nominal 1.8V) DDR/Bus Pad Supply Voltage (nominal 2.5V) SDR/Bus Pad Supply Voltage (nominal 3.3V) $I_{OH} = -5.0$ mA for all modes	SDV_{OH}	$SDV_{DD} - 0.35$ 2.1 2.4	— — —	V
SDRAM and FlexBus Output Low Voltage Mobile DDR/Bus Input High Voltage (nominal 1.8V) DDR/Bus Pad Supply Voltage (nominal 2.5V) SDR/Bus Pad Supply Voltage (nominal 3.3V) $I_{OL} = 5.0$ mA for all modes	SDV_{OL}	— — —	0.3 0.3 0.5	V
Input Leakage Current $V_{in} = V_{DD}$ or V_{SS} , Input-only pins	I_{in}	-1.0	1.0	μ A
Weak Internal Pull-Up Device Current, tested at V_{IL} Max. ¹	I_{APU}	-10	-130	μ A
Input Capacitance ² All input-only pins All input/output (three-state) pins	C_{in}	— —	7 7	pF

¹ Refer to the signals section for pins having weak internal pull-up devices.

² This parameter is characterized before qualification rather than 100% tested.

5.5 Oscillator and PLL Electrical Characteristics

Table 8. PLL Electrical Characteristics

Num	Characteristic	Symbol	Min. Value	Max. Value	Unit
1	PLL Reference Frequency Range Crystal reference External reference	$f_{ref_crystal}$ f_{ref_ext}	12 12	25^1 40^1	MHz MHz
2	Core frequency CLKOUT Frequency ²	f_{sys} $f_{sys/3}$	488×10^{-6} 163×10^{-6}	240 80	MHz MHz
3	Crystal Start-up Time ^{3, 4}	t_{cst}	—	10	ms
4	EXTAL Input High Voltage Crystal Mode ⁵ All other modes (External, Limp)	V_{IHEXT} V_{IHEXT}	$V_{XTAL} + 0.4$ $E_{VDD}/2 + 0.4$	— —	V V
5	EXTAL Input Low Voltage Crystal Mode ⁵ All other modes (External, Limp)	V_{ILEXT} V_{ILEXT}	— —	$V_{XTAL} - 0.4$ $E_{VDD}/2 - 0.4$	V V
7	PLL Lock Time ^{3, 6}	t_{pll}	—	50000	CLKIN
8	Duty Cycle of reference ³	t_{dc}	40	60	%
9	XTAL Current	I_{XTAL}	1	3	mA
10	Total on-chip stray capacitance on XTAL	C_{S_XTAL}		1.5	pF
11	Total on-chip stray capacitance on EXTAL	C_{S_EXTAL}		1.5	pF

Table 8. PLL Electrical Characteristics (continued)

Num	Characteristic	Symbol	Min. Value	Max. Value	Unit
12	Crystal capacitive load	C_L		See crystal spec	
13	Discrete load capacitance for XTAL	C_{L_XTAL}		$2 \cdot C_L - C_{S_XTAL} - C_{PCB_XTAL}$ ⁷	pF
14	Discrete load capacitance for EXTAL	C_{L_EXTAL}		$2 \cdot C_L - C_{S_EXTAL} - C_{PCB_EXTAL}$ ⁷	pF
17	CLKOUT Period Jitter, ^{3, 4, 7, 8, 9} Measured at f_{SYS} Max Peak-to-peak Jitter (Clock edge to clock edge) Long Term Jitter	C_{jitter}	— —	10 TBD	% $f_{sys}/3$ % $f_{sys}/3$
18	Frequency Modulation Range Limit ^{3, 10, 11} (f_{sys} Max must not be exceeded)	C_{mod}	0.8	2.2	% $f_{sys}/3$
19	VCO Frequency. $f_{vco} = (f_{ref} \cdot PFD)/4$	f_{vco}	350	540	MHz

¹ The maximum allowable input clock frequency when booting with the PLL enabled is 24MHz. For higher input clock frequencies the processor must boot in LIMP mode to avoid violating the maximum allowable CPU frequency.

² All internal registers retain data at 0 Hz.

³ This parameter is guaranteed by characterization before qualification rather than 100% tested.

⁴ Proper PC board layout procedures must be followed to achieve specifications.

⁵ This parameter is guaranteed by design rather than 100% tested.

⁶ This specification is the PLL lock time only and does not include oscillator start-up time.

⁷ C_{PCB_EXTAL} and C_{PCB_XTAL} are the measured PCB stray capacitances on EXTAL and XTAL, respectively.

⁸ Jitter is the average deviation from the programmed frequency measured over the specified interval at maximum f_{sys} . Measurements are made with the device powered by filtered supplies and clocked by a stable external clock signal. Noise injected into the PLL circuitry via PLL V_{DD} , EV_{DD} , and V_{SS} and variation in crystal oscillator frequency increase the C_{jitter} percentage for a given interval.

⁹ Values are with frequency modulation disabled. If frequency modulation is enabled, jitter is the sum of $C_{jitter} + C_{mod}$.

¹⁰ Modulation percentage applies over an interval of 10 μ s, or equivalently the modulation rate is 100 KHz.

¹¹ Modulation range determined by hardware design.

5.6 External Interface Timing Characteristics

Table 9 lists processor bus input timings.

NOTE

All processor bus timings are synchronous; that is, input setup/hold and output delay with respect to the rising edge of a reference clock. The reference clock is the FB_CLK output.

All other timing relationships can be derived from these values. Timings listed in Table 9 are shown in Figure 7 and Figure 8.

* The timings are also valid for inputs sampled on the negative clock edge.

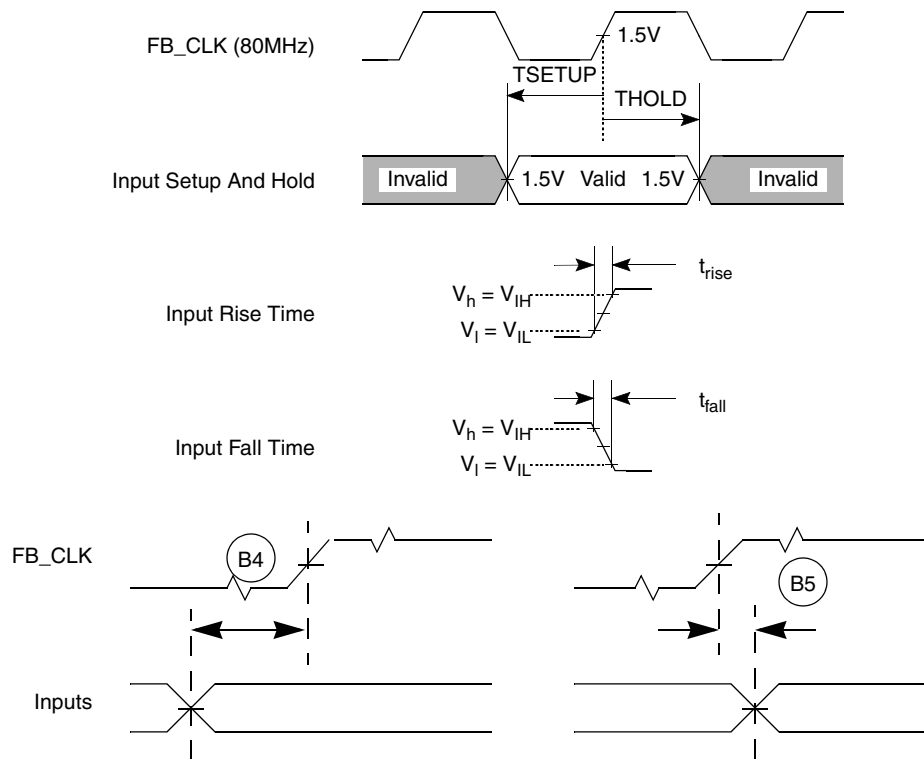

Figure 6. General Input Timing Requirements

5.6.1 FlexBus

A multi-function external bus interface called FlexBus is provided with basic functionality to interface to slave-only devices up to a maximum bus frequency of 80MHz. It can be directly connected to asynchronous or synchronous devices such as external boot ROMs, flash memories, gate-array logic, or other simple target (slave) devices with little or no additional circuitry. For asynchronous devices a simple chip-select based interface can be used. The FlexBus interface has six general purpose chip-selects ($\overline{\text{FB_CS}}[5:0]$) which can be configured to be distributed between the FlexBus or SDRAM memory interfaces. Chip-select, $\overline{\text{FB_CS}}0$ can be dedicated to boot ROM access and can be programmed to be byte (8 bits), word (16 bits), or longword (32 bits) wide. Control signal timing is compatible with common ROM/flash memories.

5.6.1.1 FlexBus AC Timing Characteristics

The following timing numbers indicate when data is latched or driven onto the external bus, relative to the system clock.

Table 9. FlexBus AC Timing Specifications

Num	Characteristic	Symbol	Min	Max	Unit
—	Frequency of Operation	$f_{\text{sys}/3}$	—	80	Mhz
FB1	Clock Period (FB_CLK)	$t_{\text{FBCK}} (t_{\text{cyc}})$	12.5	—	ns
FB2	Address, Data, and Control Output Valid ($A[23:0]$, $D[31:0]$, $\overline{\text{FB_CS}}[5:0]$, R/\overline{W} , $\overline{\text{TS}}$, $\overline{\text{BE/BWE}}[3:0]$ and $\overline{\text{OE}}$) ¹	t_{FBCHDCV}	—	7.0	ns
FB3	Address, Data, and Control Output Hold ($A[23:0]$, $D[31:0]$, $\overline{\text{FB_CS}}[5:0]$, R/\overline{W} , $\overline{\text{TS}}$, $\overline{\text{BE/BWE}}[3:0]$, and $\overline{\text{OE}}$) ^{1,2}	t_{FBCHDCI}	1	—	ns

Table 9. FlexBus AC Timing Specifications (continued)

Num	Characteristic	Symbol	Min	Max	Unit
FB4	Data Input Setup	t_{DVFBCH}	3.5	—	ns
FB5	Data Input Hold	t_{DIFBCH}	0	—	ns
FB6	Transfer Acknowledge (\overline{TA}) Input Setup	t_{CVFBCH}	4	—	ns
FB7	Transfer Acknowledge (\overline{TA}) Input Hold	t_{CIFBCH}	0	—	ns

¹ Timing for chip selects only applies to the $\overline{FB_CS}[5:0]$ signals. Please see [Section 5.7.2, “DDR SDRAM AC Timing Characteristics”](#) for $\overline{SD_CS}[3:0]$ timing.

² The FlexBus supports programming an extension of the address hold. Please consult the *Reference Manual* for more information.

NOTE

The processor drives the data lines during the first clock cycle of the transfer with the full 32-bit address. This may be ignored by standard connected devices using non-multiplexed address and data buses. However, some applications may find this feature beneficial.

The address and data busses are muxed between the FlexBus and SDRAM controller. At the end of the read and write bus cycles the address signals are indeterminate.

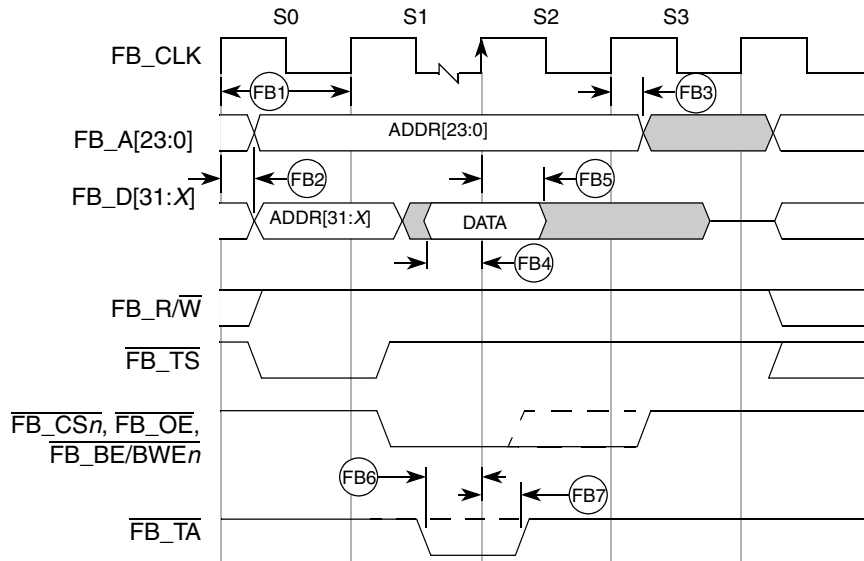

Figure 7. FlexBus Read Timing

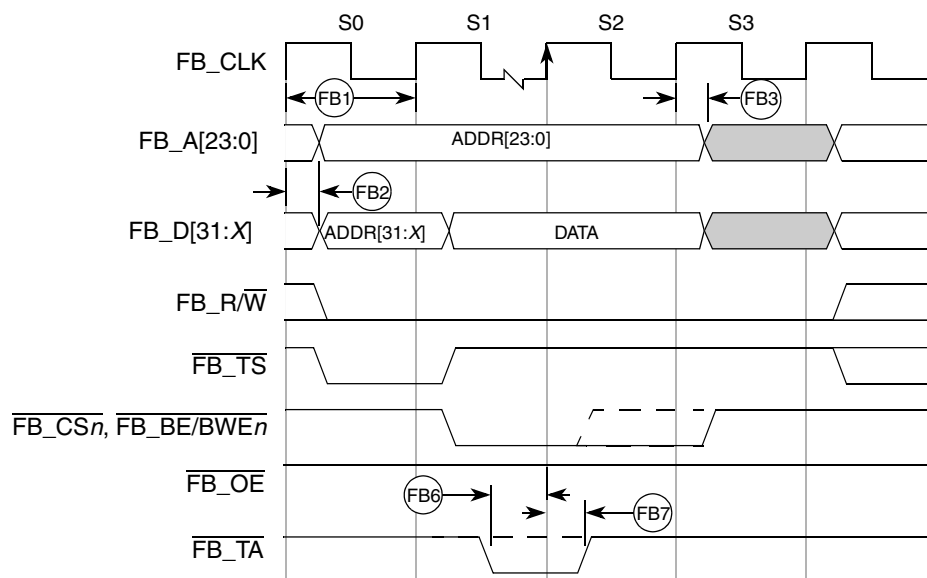

Figure 8. FlexBus Write Timing

5.7 SDRAM Bus

The SDRAM controller supports accesses to main SDRAM memory from any internal master. It supports standard SDRAM or double data rate (DDR) SDRAM, but it does not support both at the same time.

5.7.1 SDR SDRAM AC Timing Characteristics

The following timing numbers indicate when data is latched or driven onto the external bus, relative to the memory bus clock, when operating in SDR mode on write cycles and relative to SD_DQS on read cycles. The device's SDRAM controller is a DDR controller that has an SDR mode. Because it is designed to support DDR, a DQS pulse must remain supplied to the device for each data beat of an SDR read. The processor accomplishes this by asserting a signal named SD_SDR_DQS during read cycles. Care must be taken during board design to adhere to the following guidelines and specs with regard to the SD_SDR_DQS signal and its usage.

Table 10. SDR Timing Specifications

Symbol	Characteristic	Symbol	Min	Max	Unit
•	Frequency of Operation ¹	•	TBD	80	MHz
SD1	Clock Period ²	t_{SDCK}	12.5	TBD	ns
SD3	Pulse Width High ³	t_{SDCKH}	0.45	0.55	SD_CLK
SD4	Pulse Width Low ⁴	t_{SDCKL}	0.45	0.55	SD_CLK
SD5	Address, $\overline{SD_CKE}$, $\overline{SD_CAS}$, $\overline{SD_RAS}$, $\overline{SD_WE}$, $\overline{SD_BA}$, $\overline{SD_CS}[1:0]$ - Output Valid	$t_{SDCHACV}$	—	$0.5 \times SD_CLK + 1.0$	ns
SD6	Address, $\overline{SD_CKE}$, $\overline{SD_CAS}$, $\overline{SD_RAS}$, $\overline{SD_WE}$, $\overline{SD_BA}$, $\overline{SD_CS}[1:0]$ - Output Hold	$t_{SDCHACI}$	2.0	—	ns
SD7	SD_SDR_DQS Output Valid ⁵	t_{DQSOV}	—	Self timed	ns
SD8	SD_DQS[3:0] input setup relative to SD_CLK ⁶	$t_{DQVSDCH}$	$0.25 \times SD_CLK$	$0.40 \times SD_CLK$	ns

Table 10. SDR Timing Specifications (continued)

Symbol	Characteristic	Symbol	Min	Max	Unit
SD9	SD_DQS[3:2] input hold relative to SD_CLK ⁷	t _{DQISDCH}	Does not apply. 0.5×SD_CLK fixed width.		
SD10	Data (D[31:0]) Input Setup relative to SD_CLK (reference only) ⁸	t _{DVSDCH}	0.25 × SD_CLK	—	ns
SD11	Data Input Hold relative to SD_CLK (reference only)	t _{DISDCH}	1.0	—	ns
SD12	Data (D[31:0]) and Data Mask(SD_DQM[3:0]) Output Valid	t _{SDCHDMV}	—	0.75 × SD_CLK + 0.5	ns
SD13	Data (D[31:0]) and Data Mask (SD_DQM[3:0]) Output Hold	t _{SDCHDMI}	1.5	—	ns

- ¹ The FlexBus and SDRAM clock operates at the same frequency of the internal bus clock. See the PLL chapter of the *MCF5329 Reference Manual* for more information on setting the SDRAM clock rate.
- ² SD_CLK is one SDRAM clock in (ns).
- ³ Pulse width high plus pulse width low cannot exceed min and max clock period.
- ⁴ Pulse width high plus pulse width low cannot exceed min and max clock period.
- ⁵ SD_DQS is designed to pulse 0.25 clock before the rising edge of the memory clock. This is a guideline only. Subtle variation from this guideline is expected. SD_DQS only pulses during a read cycle and one pulse occurs for each data beat.
- ⁶ SDR_DQS is designed to pulse 0.25 clock before the rising edge of the memory clock. This spec is a guideline only. Subtle variation from this guideline is expected. SDR_DQS only pulses during a read cycle and one pulse occurs for each data beat.
- ⁷ The SDR_DQS pulse is designed to be 0.5 clock in width. The timing of the rising edge is most important. The falling edge does not affect the memory controller.
- ⁸ Because a read cycle in SDR mode uses the DQS circuit within the device, it is most critical that the data valid window be centered 1/4 clk after the rising edge of DQS. Ensuring that this happens results in successful SDR reads. The input setup spec is provided as guidance.

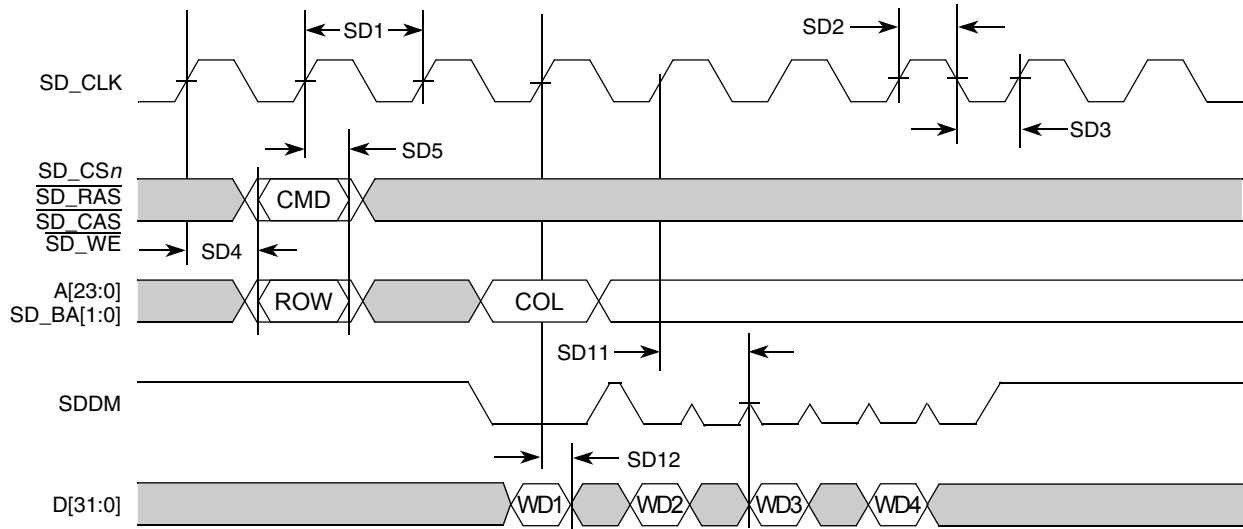

Figure 9. SDR Write Timing

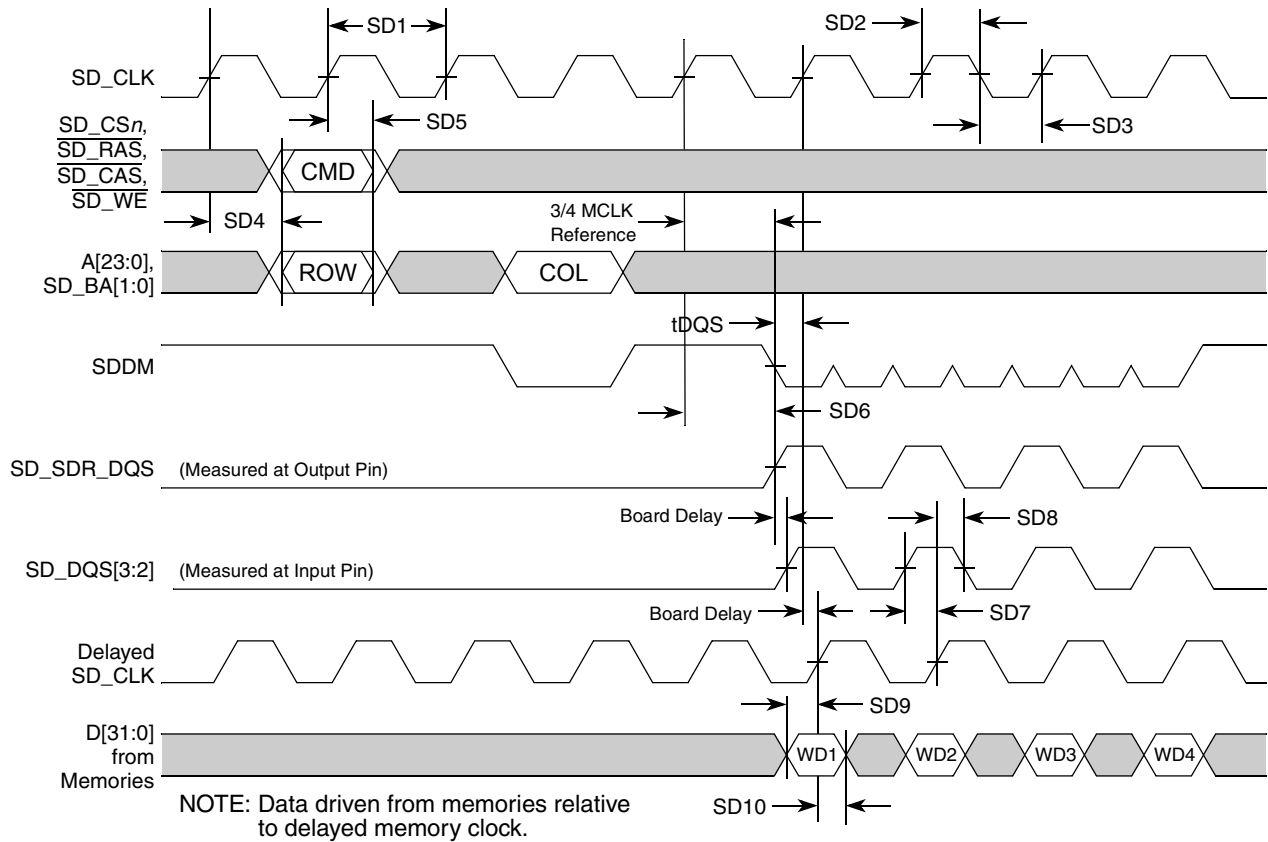

Figure 10. SDR Read Timing

5.7.2 DDR SDRAM AC Timing Characteristics

When using the SDRAM controller in DDR mode, the following timing numbers must be followed to properly latch or drive data onto the memory bus. All timing numbers are relative to the four DQS byte lanes.

Table 11. DDR Timing Specifications

Num	Characteristic	Symbol	Min	Max	Unit
•	Frequency of Operation	t_{DDCK}	TBD	80	Mhz
DD1	Clock Period ¹	t_{DDSK}	12.5	TBD	ns
DD2	Pulse Width High ²	t_{DDCKH}	0.45	0.55	SD_CLK
DD3	Pulse Width Low ³	t_{DDCKL}	0.45	0.55	SD_CLK
DD4	Address, $\overline{SD_CKE}$, $\overline{SD_CAS}$, $\overline{SD_RAS}$, $\overline{SD_WE}$, $\overline{SD_CS}[1:0]$ - Output Valid ³	$t_{SDCHACV}$	—	$0.5 \times SD_CLK + 1.0$	ns
DD5	Address, $\overline{SD_CKE}$, $\overline{SD_CAS}$, $\overline{SD_RAS}$, $\overline{SD_WE}$, $\overline{SD_CS}[1:0]$ - Output Hold	$t_{SDCHACI}$	2.0	—	ns
DD6	Write Command to first DQS Latching Transition	t_{CMDVDQ}	—	1.25	SD_CLK
DD7	Data and Data Mask Output Setup (DQ-->DQS) Relative to DQS (DDR Write Mode) ^{4, 5}	t_{DQDMV}	1.5	—	ns

Table 11. DDR Timing Specifications (continued)

Num	Characteristic	Symbol	Min	Max	Unit
DD8	Data and Data Mask Output Hold (DQS-->DQ) Relative to DQS (DDR Write Mode) ⁶	t_{DQDMI}	1.0	—	ns
DD9	Input Data Skew Relative to DQS (Input Setup) ⁷	t_{DQDQ}	—	1	ns
DD10	Input Data Hold Relative to DQS ⁸	t_{DIDQ}	$0.25 \times SD_CLK$ + 0.5ns	—	ns
DD11	DQS falling edge from SDCLK rising (output hold time)	$t_{DQLSDCH}$	0.5	—	ns
DD12	DQS input read preamble width	t_{DQRPRE}	0.9	1.1	SD_CLK
DD13	DQS input read postamble width	t_{DQRPST}	0.4	0.6	SD_CLK
DD14	DQS output write preamble width	t_{DQWPRE}	0.25		SD_CLK
DD15	DQS output write postamble width	t_{DQWPST}	0.4	0.6	SD_CLK

¹ SD_CLK is one SDRAM clock in (ns).

² Pulse width high plus pulse width low cannot exceed min and max clock period.

³ Command output valid should be 1/2 the memory bus clock (SD_CLK) plus some minor adjustments for process, temperature, and voltage variations.

⁴ This specification relates to the required input setup time of today's DDR memories. The processor's output setup should be larger than the input setup of the DDR memories. If it is not larger, the input setup on the memory is in violation. MEM_DATA[31:24] is relative to MEM_DQS[3], MEM_DATA[23:16] is relative to MEM_DQS[2], MEM_DATA[15:8] is relative to MEM_DQS[1], and MEM_[7:0] is relative MEM_DQS[0].

⁵ The first data beat is valid before the first rising edge of DQS and after the DQS write preamble. The remaining data beats are valid for each subsequent DQS edge.

⁶ This specification relates to the required hold time of today's DDR memories. MEM_DATA[31:24] is relative to MEM_DQS[3], MEM_DATA[23:16] is relative to MEM_DQS[2], MEM_DATA[15:8] is relative to MEM_DQS[1], and MEM_[7:0] is relative MEM_DQS[0].

⁷ Data input skew is derived from each DQS clock edge. It begins with a DQS transition and ends when the last data line becomes valid. This input skew must include DDR memory output skew and system level board skew (due to routing or other factors).

⁸ Data input hold is derived from each DQS clock edge. It begins with a DQS transition and ends when the first data line becomes invalid.

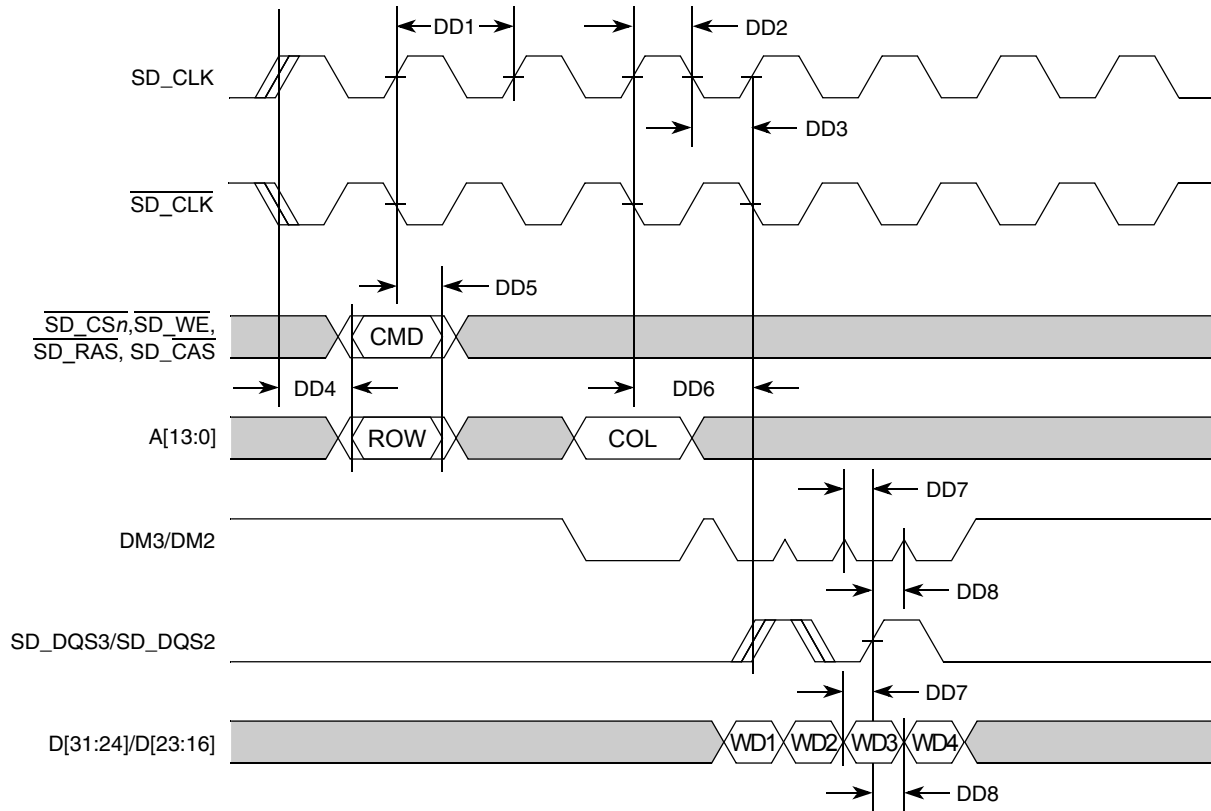

Figure 11. DDR Write Timing

Electrical Characteristics

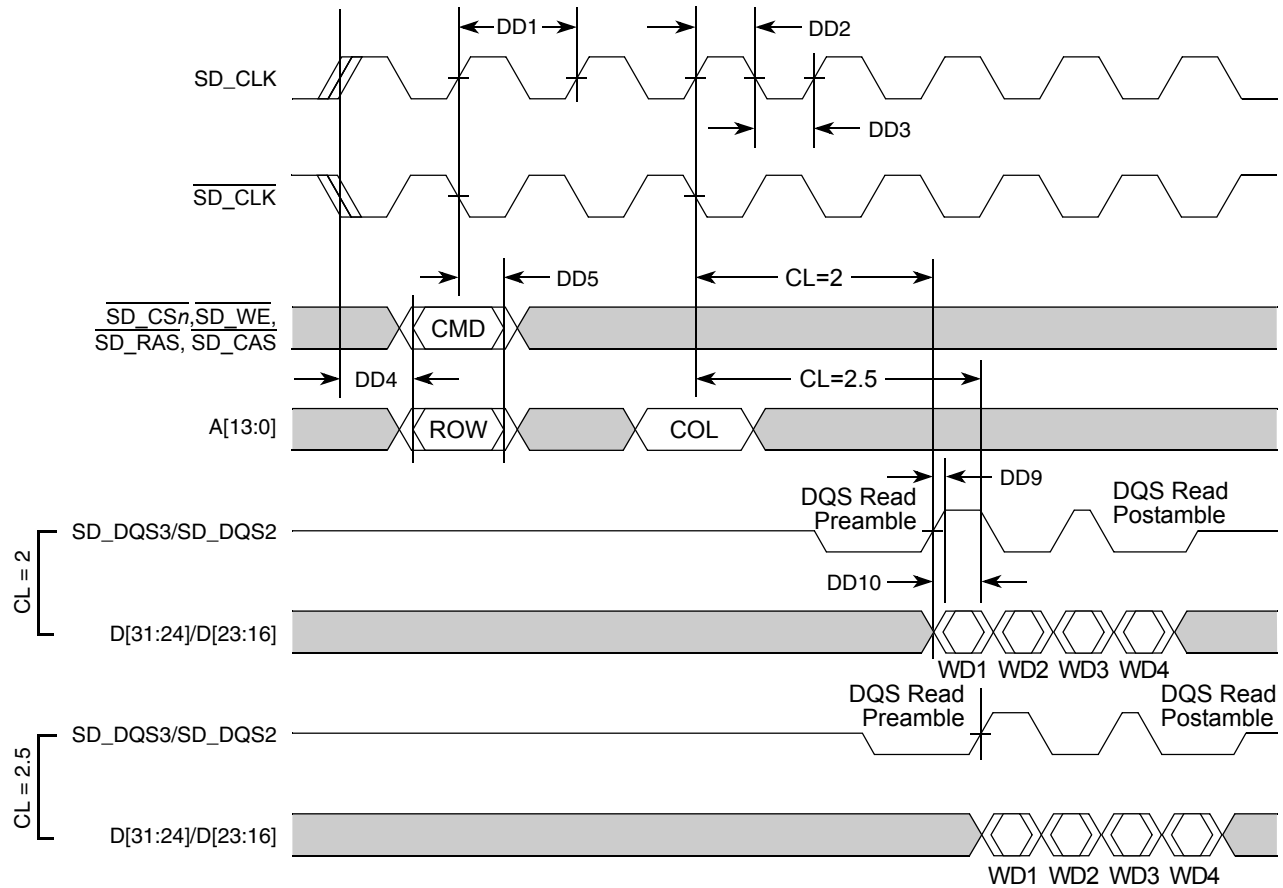

Figure 12. DDR Read Timing

5.8 General Purpose I/O Timing

Table 12. GPIO Timing¹

Num	Characteristic	Symbol	Min	Max	Unit
G1	FB_CLK High to GPIO Output Valid	t_{CHPOV}	—	10	ns
G2	FB_CLK High to GPIO Output Invalid	t_{CHPOI}	1.5	—	ns
G3	GPIO Input Valid to FB_CLK High	t_{PVCH}	9	—	ns
G4	FB_CLK High to GPIO Input Invalid	t_{CHPI}	1.5	—	ns

¹ GPIO pins include: \overline{IRQ}_n , PWM, UART, FlexCAN, and Timer pins.

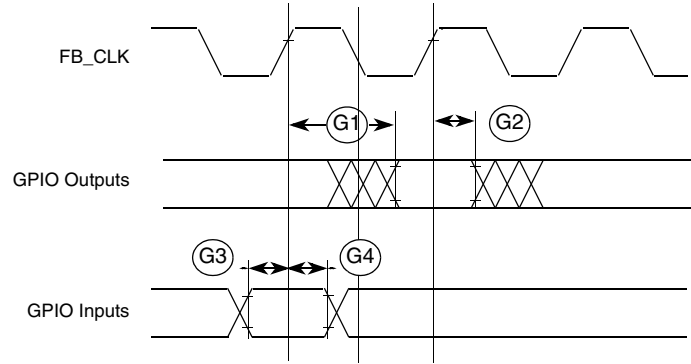

Figure 13. GPIO Timing

5.9 Reset and Configuration Override Timing

Table 13. Reset and Configuration Override Timing

Num	Characteristic	Symbol	Min	Max	Unit
R1	$\overline{\text{RESET}}$ Input valid to FB_CLK High	t_{RVCH}	9	—	ns
R2	FB_CLK High to $\overline{\text{RESET}}$ Input invalid	t_{CHRI}	1.5	—	ns
R3	$\overline{\text{RESET}}$ Input valid Time ¹	t_{RIVT}	5	—	t_{CYC}
R4	FB_CLK High to $\overline{\text{RSTOUT}}$ Valid	t_{CHROV}	—	10	ns
R5	$\overline{\text{RSTOUT}}$ valid to Config. Overrides valid	t_{ROVCV}	0	—	ns
R6	Configuration Override Setup Time to $\overline{\text{RSTOUT}}$ invalid	t_{COS}	20	—	t_{CYC}
R7	Configuration Override Hold Time after $\overline{\text{RSTOUT}}$ invalid	t_{COH}	0	—	ns
R8	$\overline{\text{RSTOUT}}$ invalid to Configuration Override High Impedance	t_{ROICZ}	—	1	t_{CYC}

¹ During low power STOP, the synchronizers for the $\overline{\text{RESET}}$ input are bypassed and $\overline{\text{RESET}}$ is asserted asynchronously to the system. Thus, $\overline{\text{RESET}}$ must be held a minimum of 100 ns.

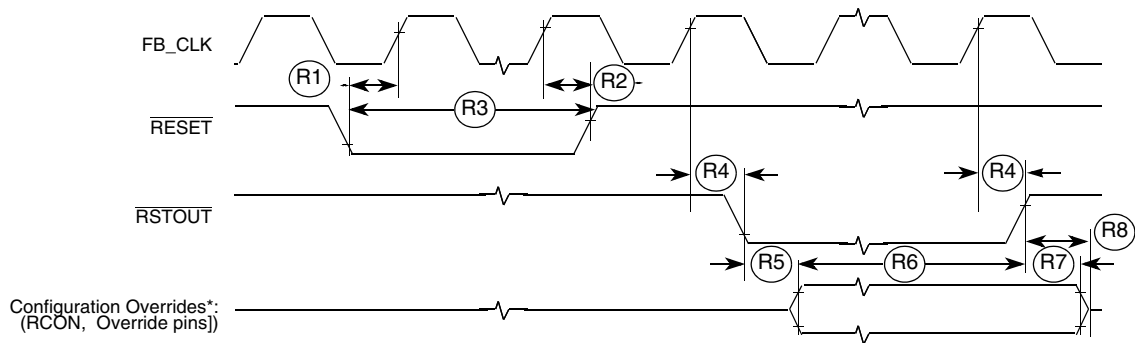

Figure 14. $\overline{\text{RESET}}$ and Configuration Override Timing

NOTE

Refer to the CCM chapter of the *MCF5329 Reference Manual* for more information.

5.10 LCD Controller Timing Specifications

This sections lists the timing specifications for the LCD Controller.

Table 14. LCD_LSCLK Timing

Num	Parameter	Minimum	Maximum	Unit
T1	LCD_LSCLK Period	25	2000	ns
T2	Pixel data setup time	11	—	ns
T3	Pixel data up time	11	—	ns

Note: The pixel clock is equal to $LCD_LSCLK / (PCD + 1)$. When it is in CSTN, TFT or monochrome mode with bus width is set and LCD_LSCLK is equal to the pixel clock. When it is in monochrome with other bus width settings, LCD_LSCLK is equal to the pixel clock divided by bus width. The polarity of LCD_LSCLK and LCD_LD signals can also be programmed.

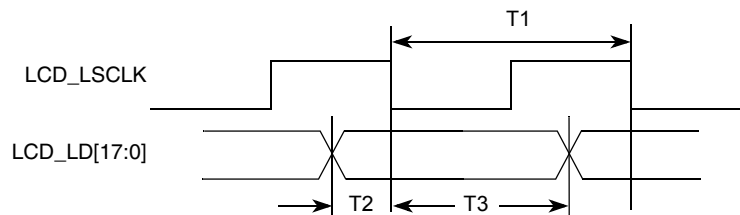

Figure 15. LCD_LSCLK to LCD_LD[17:0] timing diagram

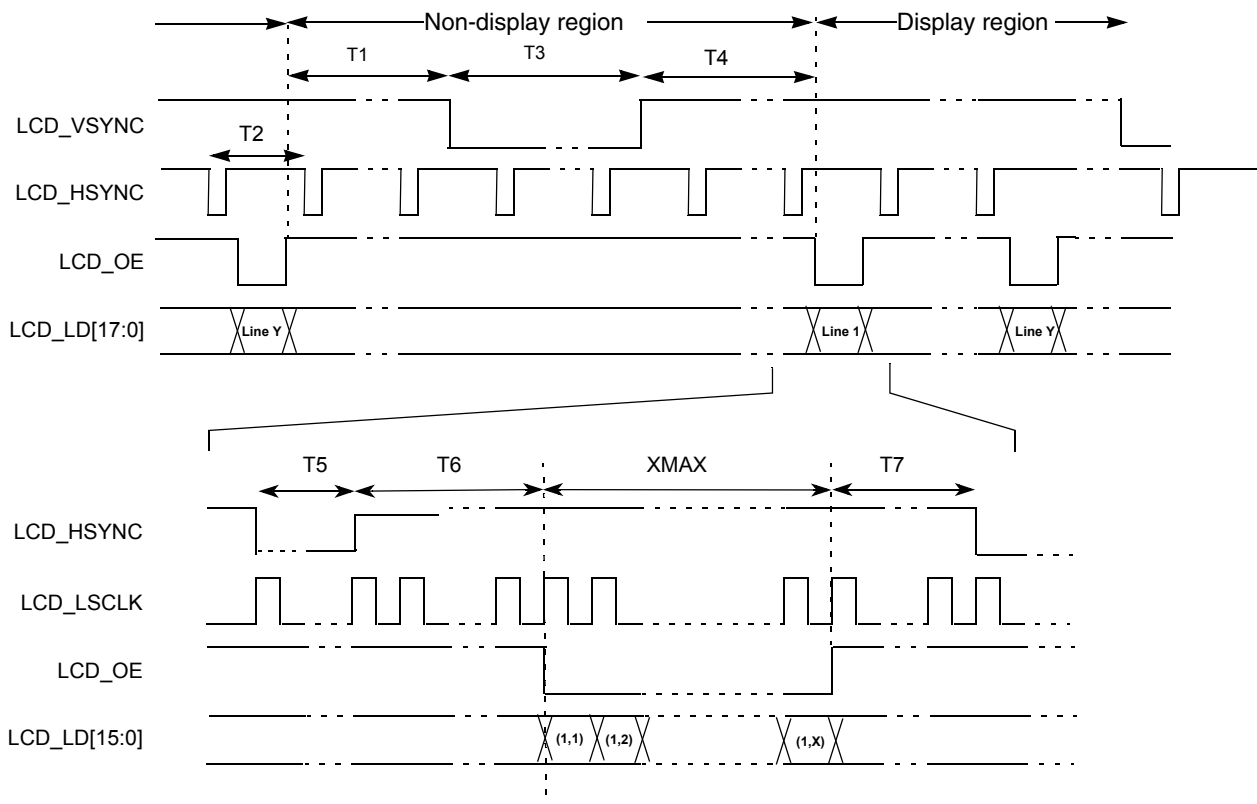

Figure 16. 4/8/12/16/18 Bit/Pixel TFT Color Mode Panel Timing

Table 15. 4/8/12/16/18 Bit/Pixel TFT Color Mode Panel Timing

Number	Description	Minimum	Value	Unit
T1	End of LCD_OE to beginning of LCD_VSYNC	$T5+T6+T7-1$	$(VWAIT1 \cdot T2)+T5+T6+T7-1$	Ts
T2	LCD_HSYNC period	—	$XMAX+T5+T6+T7$	Ts
T3	LCD_VSYNC pulse width	T2	$VWIDTH \cdot T2$	Ts
T4	End of LCD_VSYNC to beginning of LCD_OE	1	$(VWAIT2 \cdot T2)+1$	Ts
T5	LCD_HSYNC pulse width	1	$HWIDTH+1$	Ts
T6	End of LCD_HSYNC to beginning to LCD_OE	3	$HWAIT2+3$	Ts
T7	End of LCD_OE to beginning of LCD_HSYNC	1	$HWAIT1+1$	Ts

Note: Ts is the LCD_LSCLK period. LCD_VSYNC, LCD_HSYNC and LCD_OE can be programmed as active high or active low. In Figure 16, all 3 signals are active low. LCD_LSCLK can be programmed to be deactivated during the LCD_VSYNC pulse or the LCD_OE deasserted period. In Figure 16, LCD_LSCLK is always active.

Note: XMAX is defined in number of pixels in one line.

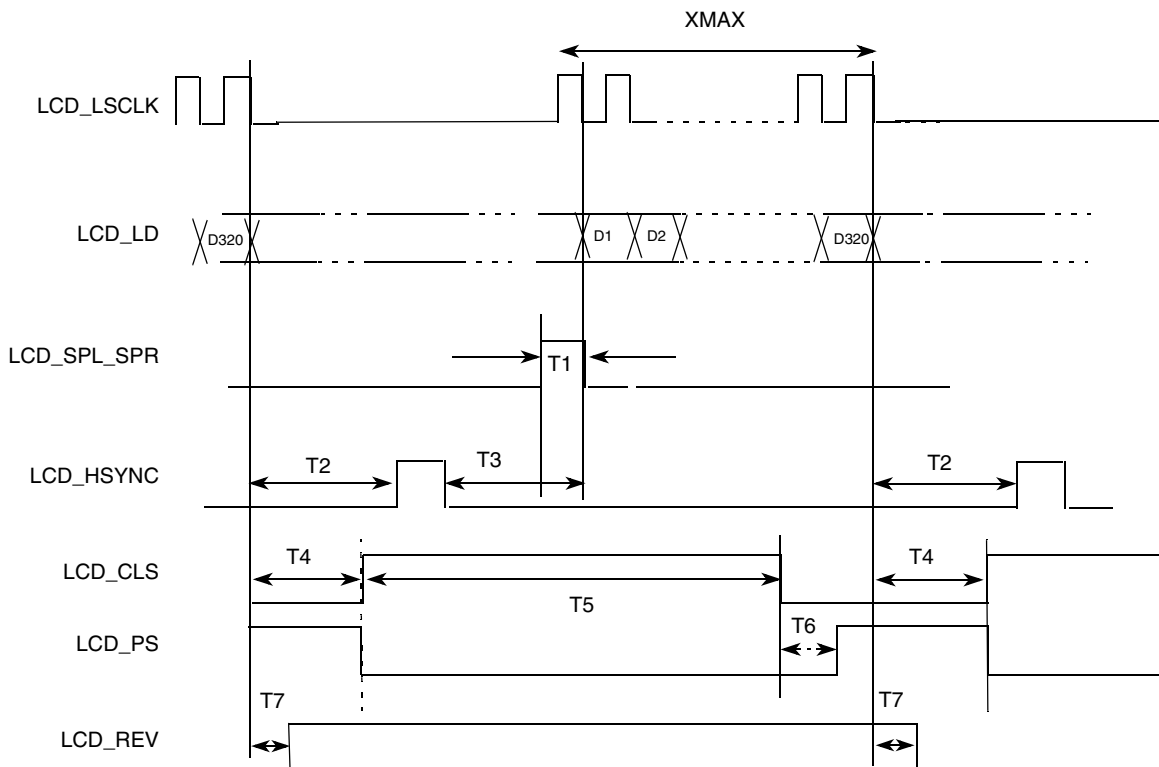

Figure 17. Sharp TFT Panel Timing

Table 16. Sharp TFT Panel Timing

Num	Description	Minimum	Value	Unit
T1	LCD_SPL/LCD_SPR pulse width	—	1	Ts
T2	End of LCD_LD of line to beginning of LCD_HSYNC	1	HWAIT1+1	Ts
T3	End of LCD_HSYNC to beginning of LCD_LD of line	4	HWAIT2 + 4	Ts
T4	LCD_CLS rise delay from end of LCD_LD of line	3	CLS_RISE_DELAY+1	Ts
T5	LCD_CLS pulse width	1	CLS_HI_WIDTH+1	Ts
T6	LCD_PS rise delay from LCD_CLS negation	0	PS_RISE_DELAY	Ts
T7	LCD_REV toggle delay from last LCD_LD of line	1	REV_TOGGLE_DELAY+1	Ts

Note: Falling of LCD_SPL/LCD_SPR aligns with first LCD_LD of line.

Note: Falling of LCD_PS aligns with rising edge of LCD_CLS.

Note: LCD_REV toggles in every LCD_HSYN period.

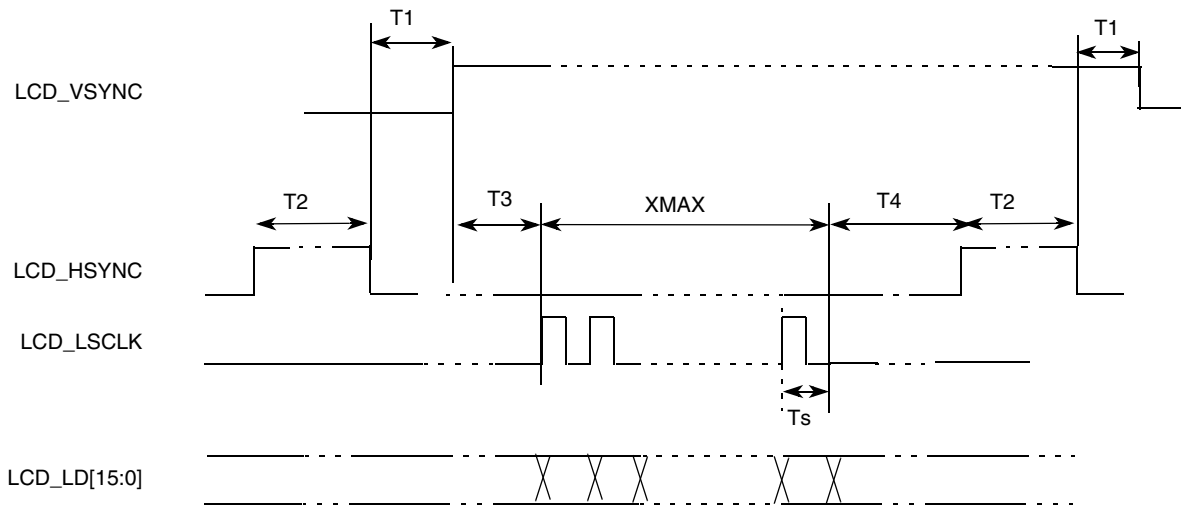

Figure 18. Non-TFT Mode Panel Timing

Table 17. Non-TFT Mode Panel Timing

Num	Description	Minimum	Value	Unit
T1	LCD_HSYNC to LCD_VSYNC delay	2	HWAIT2 + 2	Tpix
T2	LCD_HSYNC pulse width	1	HWIDTH + 1	Tpix
T3	LCD_VSYNC to LCD_LSCLK	—	$0 \leq T3 \leq Ts$	—
T4	LCD_LSCLK to LCD_HSYNC	1	HWAIT1 + 1	Tpix

Note: Ts is the LCD_LSCLK period while Tpix is the pixel clock period. LCD_VSYNC, LCD_HSYNC and LCD_LSCLK can be programmed as active high or active low. In Figure 18, all three signals are active high. When it is in CSTN mode or monochrome mode with bus width = 1, T3 = Tpix = Ts. When it is in monochrome mode with bus width = 2, 4 and 8, T3 = 1, 2 and 4 Tpix respectively.

5.11 USB On-The-Go

The MCF5329 device is compliant with industry standard USB 2.0 specification.

5.12 ULPI Timing Specification

Control and data timing requirements for the ULPI pins are given in Table 18. These timings apply in synchronous mode only. All timings are measured with either a 60 MHz input clock from the USB_CLKIN pin. The USB_CLKIN needs to maintain a 50% duty cycle. Control signals and 8-bit data are always clocked on the rising edge.

The ULPI interface on the MCF5329 processor is compliant with the industry standard definition.

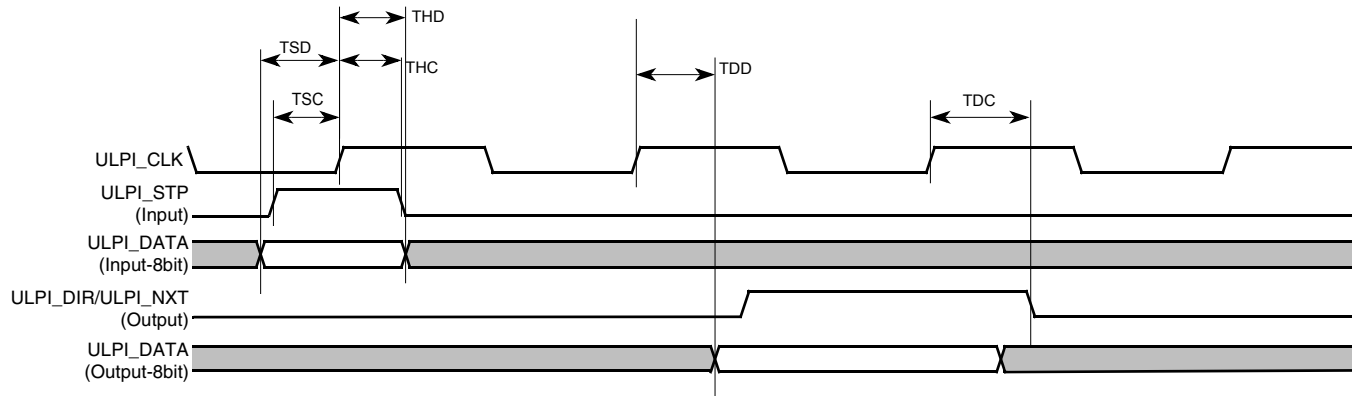

Figure 19. ULPI Timing Diagram

Table 18. ULPI Interface Timing

Parameter	Symbol	Min	Max	Units
Setup time (control in, 8-bit data in)	TSC, TSD	—	3.0	ns
Hold time (control in, 8-bit data in)	THC, THD	-1.5	—	ns
Output delay (control out, 8-bit data out)	TDC, TDD	—	6.0	ns

5.13 SSI Timing Specifications

This section provides the AC timings for the SSI in master (clocks driven) and slave modes (clocks input). All timings are given for non-inverted serial clock polarity (SSI_TCR[TSCPK] = 0, SSI_RCR[RSCKP] = 0) and a non-inverted frame sync (SSI_TCR[TFSI] = 0, SSI_RCR[RFSI] = 0). If the polarity of the clock and/or the frame sync have been inverted, all the timings remain valid by inverting the clock signal (SSI_BCLK) and/or the frame sync (SSI_FS) shown in the figures below.

Table 19. SSI Timing – Master Modes¹

Num	Description	Symbol	Min	Max	Units
S1	SSI_MCLK cycle time ²	t_{MCLK}	$8 \times t_{SYS}$	—	ns
S2	SSI_MCLK pulse width high / low		45%	55%	t_{MCLK}
S3	SSI_BCLK cycle time ³	t_{BCLK}	$8 \times t_{SYS}$	—	ns
S4	SSI_BCLK pulse width		45%	55%	t_{BCLK}
S5	SSI_BCLK to SSI_FS output valid		—	15	ns

Table 19. SSI Timing – Master Modes¹ (continued)

Num	Description	Symbol	Min	Max	Units
S6	SSI_BCLK to SSI_FS output invalid		-2	—	ns
S7	SSI_BCLK to SSI_TXD valid		—	15	ns
S8	SSI_BCLK to SSI_TXD invalid / high impedance		-4	—	ns
S9	SSI_RXD / SSI_FS input setup before SSI_BCLK		15	—	ns
S10	SSI_RXD / SSI_FS input hold after SSI_BCLK		0	—	ns

¹ All timings specified with a capacitive load of 25pF.

² SSI_MCLK can be generated from SSI_CLKIN or a divided version of the internal system clock (SYSCLK).

³ SSI_BCLK can be derived from SSI_CLKIN or a divided version of SYSCLK. If the SYSCLK is used, the minimum divider is 6. If the SSI_CLKIN input is used, the programmable dividers must be set to ensure that SSI_BCLK does not exceed $4 \times t_{SYS}$.

Table 20. SSI Timing – Slave Modes¹

Num	Description	Symbol	Min	Max	Units
S11	SSI_BCLK cycle time	t_{BCLK}	$8 \times t_{SYS}$	—	ns
S12	SSI_BCLK pulse width high/low		45%	55%	t_{BCLK}
S13	SSI_FS input setup before SSI_BCLK		10	—	ns
S14	SSI_FS input hold after SSI_BCLK		3	—	ns
S15	SSI_BCLK to SSI_TXD/SSI_FS output valid		—	15	ns
S16	SSI_BCLK to SSI_TXD/SSI_FS output invalid/high impedance		-2	—	ns
S17	SSI_RXD setup before SSI_BCLK		10	—	ns
S18	SSI_RXD hold after SSI_BCLK		3	—	ns

¹ All timings specified with a capacitive load of 25pF.

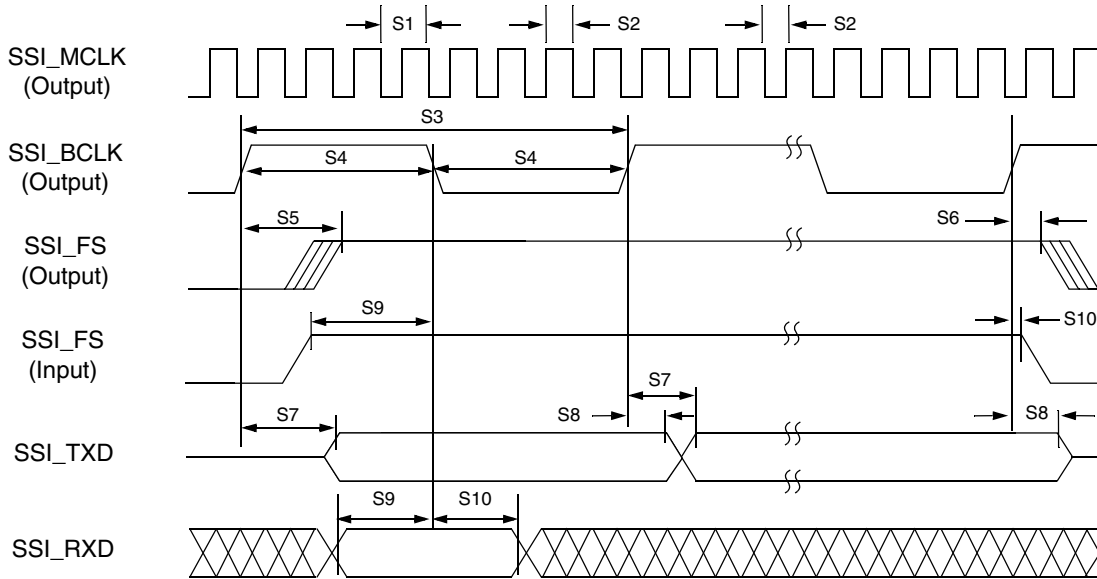

Figure 20. SSI Timing – Master Modes

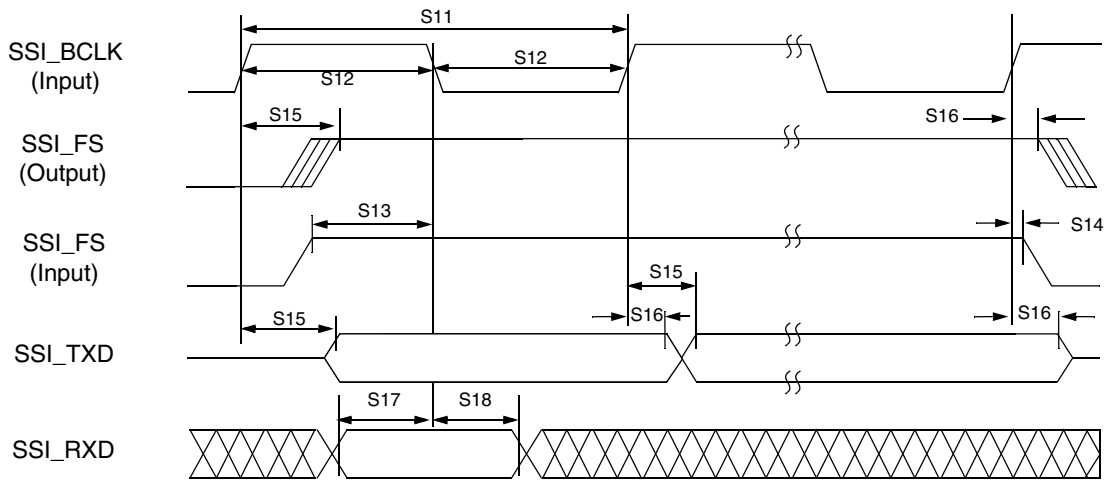

Figure 21. SSI Timing – Slave Modes

5.14 I²C Input/Output Timing Specifications

Table 21 lists specifications for the I²C input timing parameters shown in Figure 22.

Table 21. I²C Input Timing Specifications between SCL and SDA

Num	Characteristic	Min	Max	Units
I1	Start condition hold time	2	—	t _{cyc}
I2	Clock low period	8	—	t _{cyc}
I3	I2C_SCL/I2C_SDA rise time (V _{IL} = 0.5 V to V _{IH} = 2.4 V)	—	1	ms
I4	Data hold time	0	—	ns

Table 21. I²C Input Timing Specifications between SCL and SDA (continued)

Num	Characteristic	Min	Max	Units
I5	I2C_SCL/I2C_SDA fall time ($V_{IH} = 2.4\text{ V}$ to $V_{IL} = 0.5\text{ V}$)	—	1	ms
I6	Clock high time	4	—	t_{cyc}
I7	Data setup time	0	—	ns
I8	Start condition setup time (for repeated start condition only)	2	—	t_{cyc}
I9	Stop condition setup time	2	—	t_{cyc}

Table 22 lists specifications for the I²C output timing parameters shown in Figure 22.

Table 22. I²C Output Timing Specifications between SCL and SDA

Num	Characteristic	Min	Max	Units
I1 ¹	Start condition hold time	6	—	t_{cyc}
I2 ¹	Clock low period	10	—	t_{cyc}
I3 ²	I2C_SCL/I2C_SDA rise time ($V_{IL} = 0.5\text{ V}$ to $V_{IH} = 2.4\text{ V}$)	—	—	μs
I4 ¹	Data hold time	7	—	t_{cyc}
I5 ³	I2C_SCL/I2C_SDA fall time ($V_{IH} = 2.4\text{ V}$ to $V_{IL} = 0.5\text{ V}$)	—	3	ns
I6 ¹	Clock high time	10	—	t_{cyc}
I7 ¹	Data setup time	2	—	t_{cyc}
I8 ¹	Start condition setup time (for repeated start condition only)	20	—	t_{cyc}
I9 ¹	Stop condition setup time	10	—	t_{cyc}

¹ Output numbers depend on the value programmed into the IFDR; an IFDR programmed with the maximum frequency (IFDR = 0x20) results in minimum output timings as shown in Table 22. The I²C interface is designed to scale the actual data transition time to move it to the middle of the SCL low period. The actual position is affected by the prescale and division values programmed into the IFDR; however, the numbers given in Table 22 are minimum values.

² Because I2C_SCL and I2C_SDA are open-collector-type outputs, which the processor can only actively drive low, the time I2C_SCL or I2C_SDA take to reach a high level depends on external signal capacitance and pull-up resistor values.

³ Specified at a nominal 50-pF load.

Figure 22 shows timing for the values in Table 22 and Table 21.

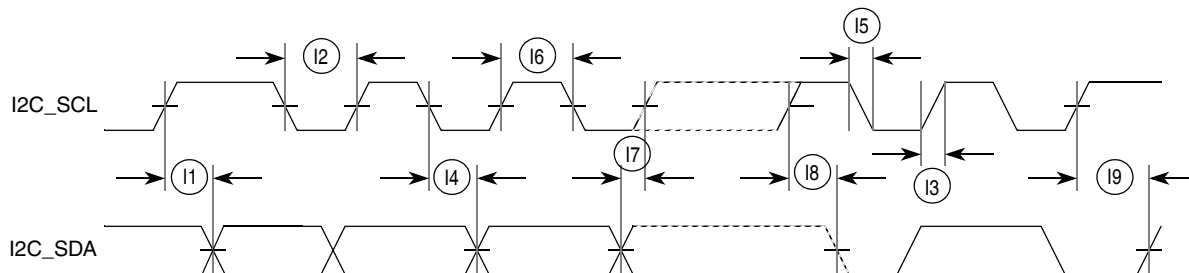

Figure 22. I²C Input/Output Timings

5.15 Fast Ethernet AC Timing Specifications

MII signals use TTL signal levels compatible with devices operating at 5.0 V or 3.3 V.

5.15.1 MII Receive Signal Timing

The receiver functions correctly up to a FEC_RXCLK maximum frequency of 25 MHz +1%. The processor clock frequency must exceed twice the FEC_RXCLK frequency.

Table 23 lists MII receive channel timings.

Table 23. MII Receive Signal Timing

Num	Characteristic	Min	Max	Unit
M1	FEC_RXD[3:0], FEC_RXDV, FEC_RXER to FEC_RXCLK setup	5	—	ns
M2	FEC_RXCLK to FEC_RXD[3:0], FEC_RXDV, FEC_RXER hold	5	—	ns
M3	FEC_RXCLK pulse width high	35%	65%	FEC_RXCLK period
M4	FEC_RXCLK pulse width low	35%	65%	FEC_RXCLK period

Figure 23 shows MII receive signal timings listed in Table 23.

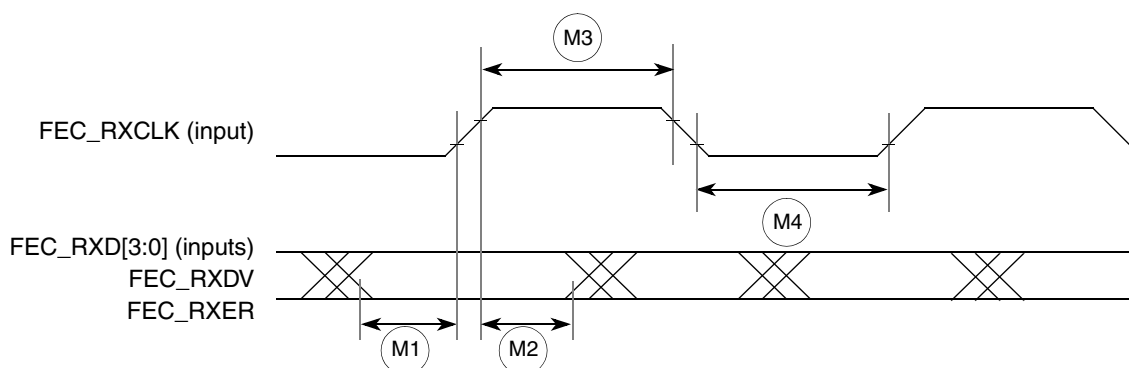

Figure 23. MII Receive Signal Timing Diagram

5.15.2 MII Transmit Signal Timing

Table 24 lists MII transmit channel timings.

The transmitter functions correctly up to a FEC_TXCLK maximum frequency of 25 MHz +1%. The processor clock frequency must exceed twice the FEC_TXCLK frequency.

Table 24. MII Transmit Signal Timing

Num	Characteristic	Min	Max	Unit
M5	FEC_TXCLK to FEC_TXD[3:0], FEC_TXEN, FEC_TXER invalid	5	—	ns
M6	FEC_TXCLK to FEC_TXD[3:0], FEC_TXEN, FEC_TXER valid	—	25	ns
M7	FEC_TXCLK pulse width high	35%	65%	FEC_TXCLK period
M8	FEC_TXCLK pulse width low	35%	65%	FEC_TXCLK period

Figure 24 shows MII transmit signal timings listed in Table 24.

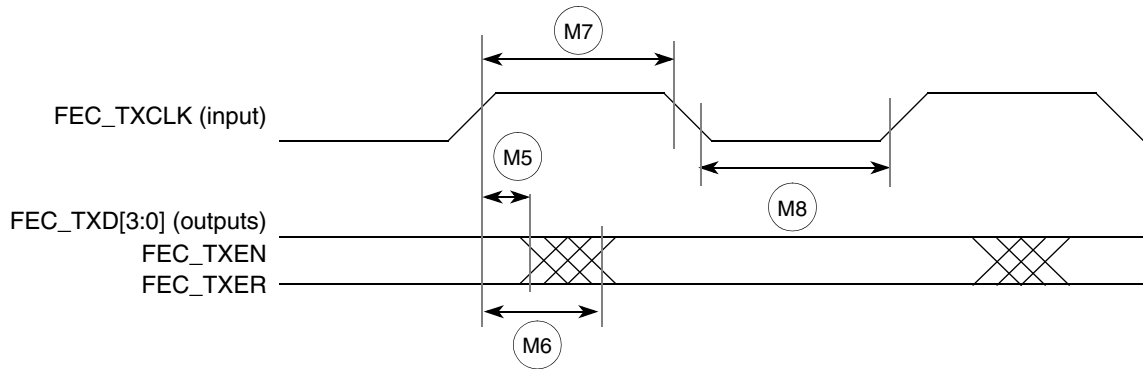

Figure 24. MII Transmit Signal Timing Diagram

5.15.3 MII Async Inputs Signal Timing

Table 25 lists MII asynchronous inputs signal timing.

Table 25. MII Async Inputs Signal Timing

Num	Characteristic	Min	Max	Unit
M9	FEC_CRIS, FEC_COL minimum pulse width	1.5	—	FEC_TXCLK period

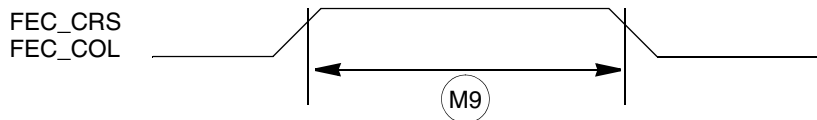

Figure 25. MII Async Inputs Timing Diagram

5.15.4 MII Serial Management Channel Timing

Table 26 lists MII serial management channel timings. The FEC functions correctly with a maximum MDC frequency of 2.5 MHz.

Table 26. MII Serial Management Channel Timing

Num	Characteristic	Min	Max	Unit
M10	FEC_MDC falling edge to FEC_MDIO output invalid (minimum propagation delay)	0	—	ns
M11	FEC_MDC falling edge to FEC_MDIO output valid (max prop delay)	—	25	ns
M12	FEC_MDIO (input) to FEC_MDC rising edge setup	10	—	ns
M13	FEC_MDIO (input) to FEC_MDC rising edge hold	0	—	ns
M14	FEC_MDC pulse width high	40%	60%	FEC_MDC period
M15	FEC_MDC pulse width low	40%	60%	FEC_MDC period

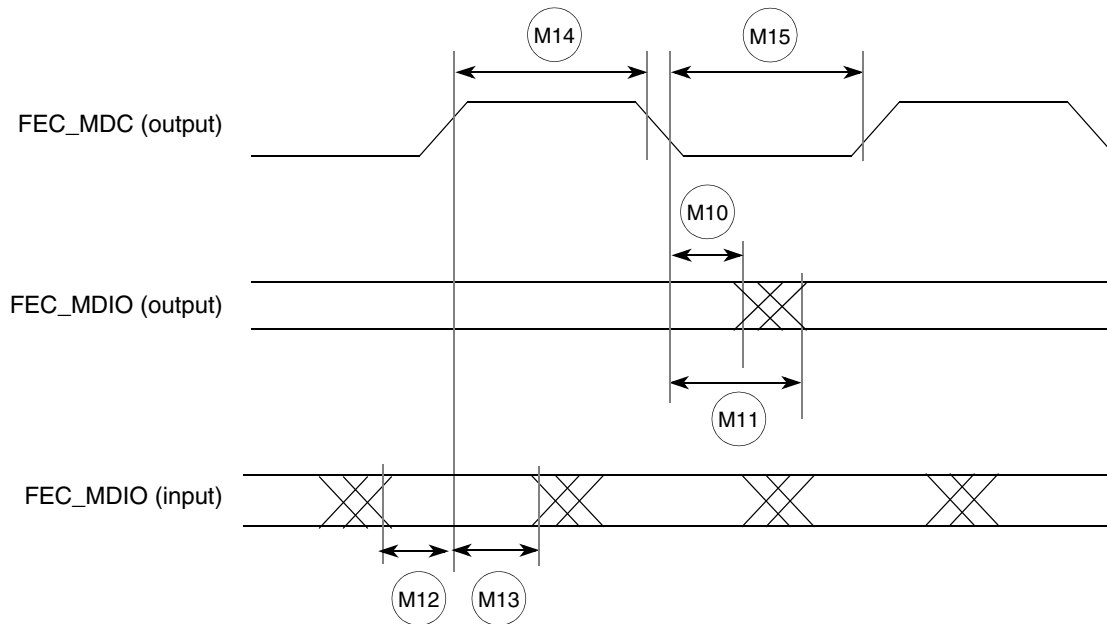

Figure 26. MII Serial Management Channel Timing Diagram

5.16 32-Bit Timer Module Timing Specifications

Table 27 lists timer module AC timings.

Table 27. Timer Module AC Timing Specifications

Name	Characteristic	Min	Max	Unit
T1	DT0IN / DT1IN / DT2IN / DT3IN cycle time	3	—	t_{CYC}
T2	DT0IN / DT1IN / DT2IN / DT3IN pulse width	1	—	t_{CYC}

5.17 QSPI Electrical Specifications

Table 28 lists QSPI timings.

Table 28. QSPI Modules AC Timing Specifications

Name	Characteristic	Min	Max	Unit
QS1	QSPI_CS[3:0] to QSPI_CLK	1	510	t_{CYC}
QS2	QSPI_CLK high to QSPI_DOUT valid.	—	10	ns
QS3	QSPI_CLK high to QSPI_DOUT invalid. (Output hold)	2	—	ns
QS4	QSPI_DIN to QSPI_CLK (Input setup)	9	—	ns
QS5	QSPI_DIN to QSPI_CLK (Input hold)	9	—	ns

Electrical Characteristics

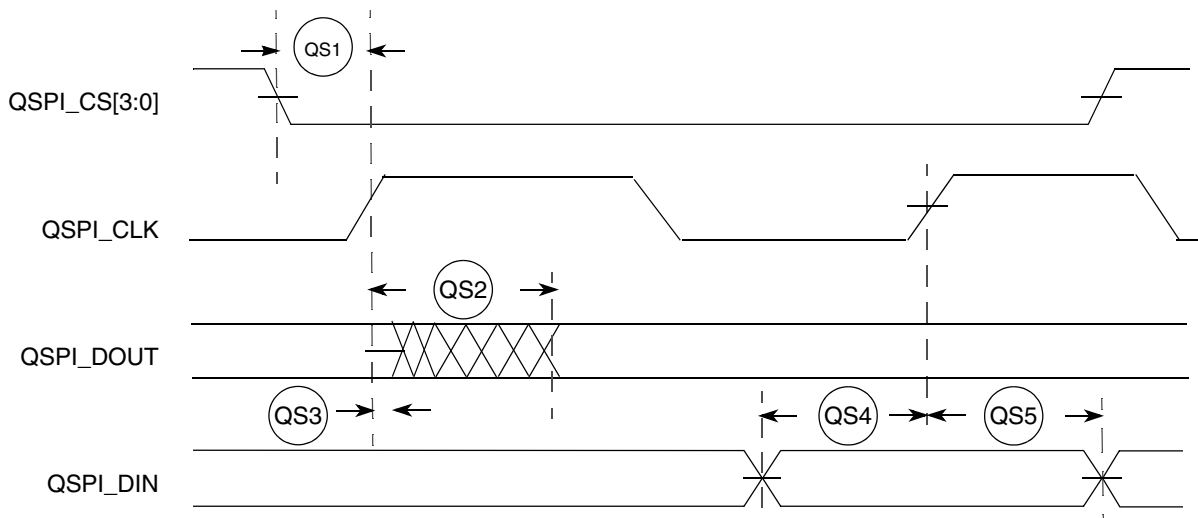

Figure 27. QSPI Timing

5.18 JTAG and Boundary Scan Timing

Table 29. JTAG and Boundary Scan Timing

Num	Characteristics ¹	Symbol	Min	Max	Unit
J1	TCLK Frequency of Operation	f_{JCYC}	DC	1/4	$f_{sys}/3$
J2	TCLK Cycle Period	t_{JCYC}	4	—	t_{CYC}
J3	TCLK Clock Pulse Width	t_{JCW}	26	—	ns
J4	TCLK Rise and Fall Times	t_{JCRF}	0	3	ns
J5	Boundary Scan Input Data Setup Time to TCLK Rise	t_{BSDST}	4	—	ns
J6	Boundary Scan Input Data Hold Time after TCLK Rise	t_{BSDHT}	26	—	ns
J7	TCLK Low to Boundary Scan Output Data Valid	t_{BSDV}	0	33	ns
J8	TCLK Low to Boundary Scan Output High Z	t_{BSDZ}	0	33	ns
J9	TMS, TDI Input Data Setup Time to TCLK Rise	t_{TAPBST}	4	—	ns
J10	TMS, TDI Input Data Hold Time after TCLK Rise	t_{TAPBHT}	10	—	ns
J11	TCLK Low to TDO Data Valid	t_{TDODV}	0	26	ns
J12	TCLK Low to TDO High Z	t_{TDODZ}	0	8	ns
J13	\overline{TRST} Assert Time	t_{TRSTAT}	100	—	ns
J14	\overline{TRST} Setup Time (Negation) to TCLK High	t_{TRSTST}	10	—	ns

¹ JTAG_EN is expected to be a static signal. Hence, specific timing is not associated with it.

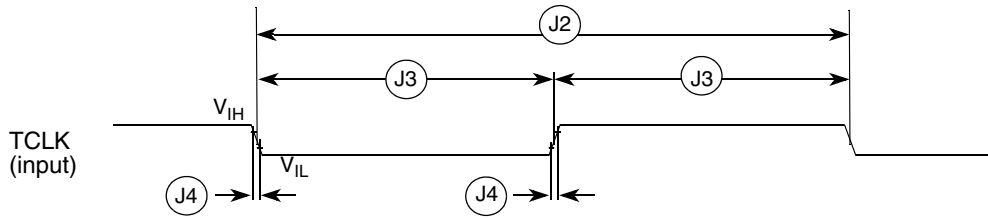

Figure 28. Test Clock Input Timing

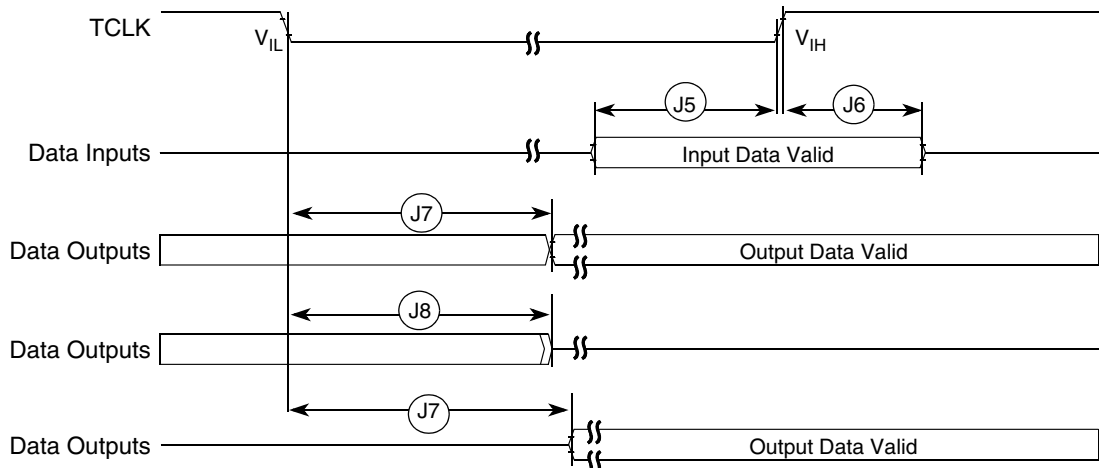

Figure 29. Boundary Scan (JTAG) Timing

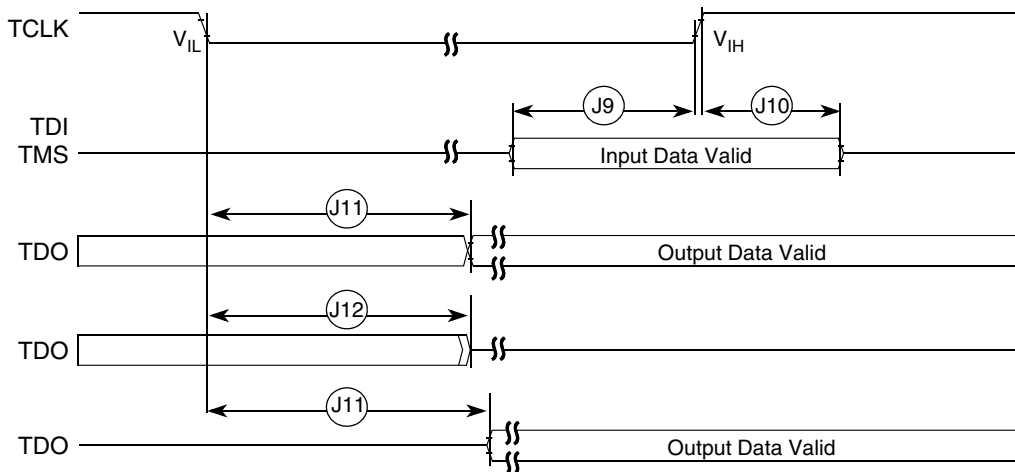

Figure 30. Test Access Port Timing

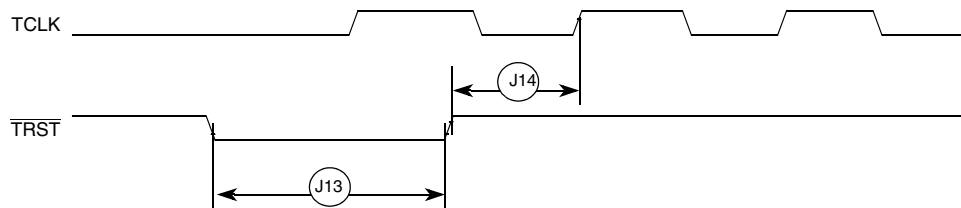

Figure 31. TRST Timing

5.19 Debug AC Timing Specifications

Table 30 lists specifications for the debug AC timing parameters shown in Figure 32.

Table 30. Debug AC Timing Specification

Num	Characteristic	Min	Max	Units
D0	PSTCLK cycle time	2	2	$t_{SYS} = 1/f_{SYS}$
D1	PSTCLK rising to PSTDDATA valid	—	3.0	ns
D2	PSTCLK rising to PSTDDATA invalid	1.5	—	ns
D3	DSI-to-DSCLK setup	1	—	PSTCLK
D4 ¹	DSCLK-to-DSO hold	4	—	PSTCLK
D5	DSCLK cycle time	5	—	PSTCLK
D6	BKPT assertion time	1	—	PSTCLK

¹ DSCLK and DSI are synchronized internally. D4 is measured from the synchronized DSCLK input relative to the rising edge of PSTCLK.

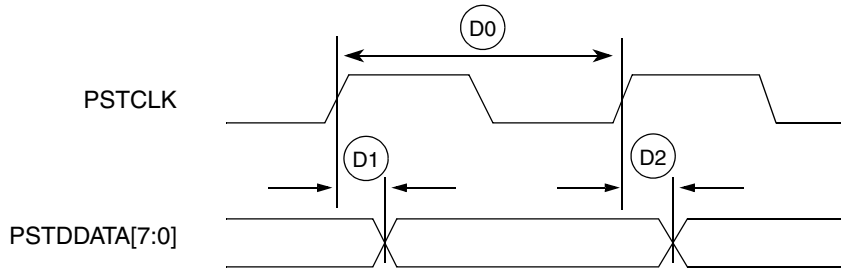

Figure 32. Real-Time Trace AC Timing

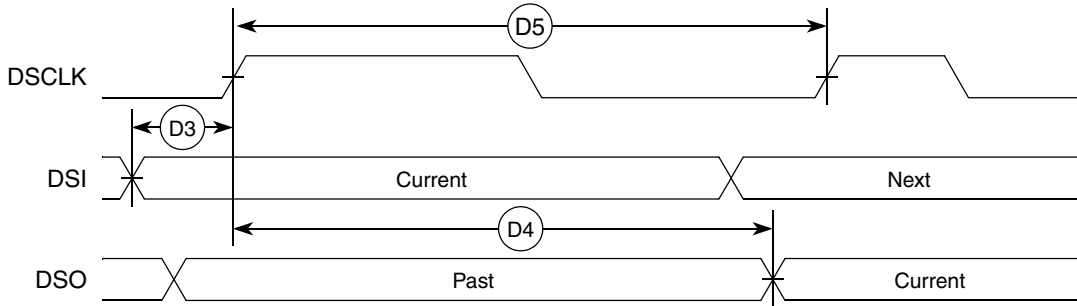

Figure 33. BDM Serial Port AC Timing

6 Current Consumption

All current consumption data is lab data measured on a single device using an evaluation board. Table 31 shows the typical power consumption in low-power modes. These current measurements are taken after executing a STOP instruction.

Table 31. Current Consumption in Low-Power Modes^{1,2}

Mode	Voltage	58 MHz (Typ) ³	64 MHz (Typ) ³	72 MHz (Typ) ³	80 MHz (Typ) ³	80 MHz (Peak) ⁴	Units
Stop Mode 3 (Stop 11) ⁵	3.3 V	3.9	3.92	4.0	4.0	4.0	mA
	1.5 V	1.04	1.04	1.04	1.04	1.08	
Stop Mode 2 (Stop 10) ⁴	3.3 V	4.69	4.72	4.8	4.8	4.8	
	1.5 V	2.69	2.69	2.70	2.70	2.75	
Stop Mode 1 (Stop 01) ⁴	3.3 V	4.72	4.73	4.81	4.81	4.81	
	1.5 V	15.28	16.44	17.85	19.91	20.42	
Stop Mode 0 (Stop 00) ⁴	3.3 V	21.65	21.68	24.33	26.13	26.16	
	1.5 V	15.47	16.63	18.06	20.12	20.67	
Wait/Doze	3.3 V	22.49	22.52	25.21	27.03	39.8	
	1.5 V	26.79	28.85	30.81	34.47	97.4	
Run	3.3 V	33.61	33.61	42.3	50.5	62.6	
	1.5 V	56.3	60.7	65.4	73.4	132.3	

¹ All values are measured with a 3.30V EV_{DD}, 3.30V SDV_{DD} and 1.5V IV_{DD} power supplies. Tests performed at room temperature with pins configured for high drive strength.

² Refer to the Power Management chapter in the *MCF532x Reference Manual* for more information on low-power modes.

³ All peripheral clocks except UART0, FlexBus, INTC0, reset controller, PLL, and edge port off before entering low power mode. All code executed from flash.

⁴ All peripheral clocks on before entering low power mode. All code is executed from flash.

⁵ See the description of the low-power control register (LCPR) in the *MCF532x Reference Manual* for more information on stop modes 0–3.

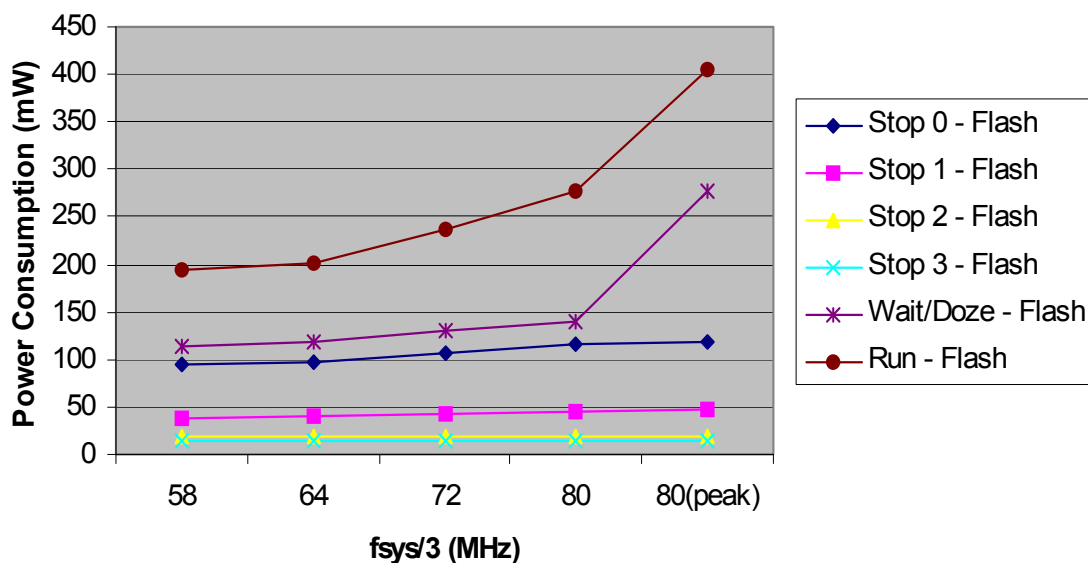

Figure 34. Current Consumption in Low-Power Modes

Table 32. Typical Active Current Consumption Specifications¹

$f_{sys/3}$ Frequency	Voltage	Typical ² Active (Flash)	Peak ³	Unit
1.333 MHz	3.3V	7.73	7.74	mA
	1.5V	2.87	3.56	
2.666 MHz	3.3V	8.57	8.60	
	1.5V	4.37	5.52	
58 MHz	3.3V	40.10	49.3	
	1.5V	65.90	91.70	
64 MHz	3.3V	44.40	54.0	
	1.5V	69.50	97.0	
72 MHz	3.3V	53.6	63.7	
	1.5V	74.6	104.7	
80 MHz	3.3V	63.0	73.7	
	1.5V	79.6	112.9	

- ¹ All values are measured with a 3.30 V EV_{DD}, 3.30 V SDV_{DD} and 1.5 V IV_{DD} power supplies. Tests performed at room temperature with pins configured for high drive strength.
- ² CPU polling a status register. All peripheral clocks except UART0, FlexBus, INTC0, reset controller, PLL, and edge port disabled.
- ³ Peak current measured while running a while(1) loop with all modules active.

Figure 35 shows the estimated maximum power consumption.

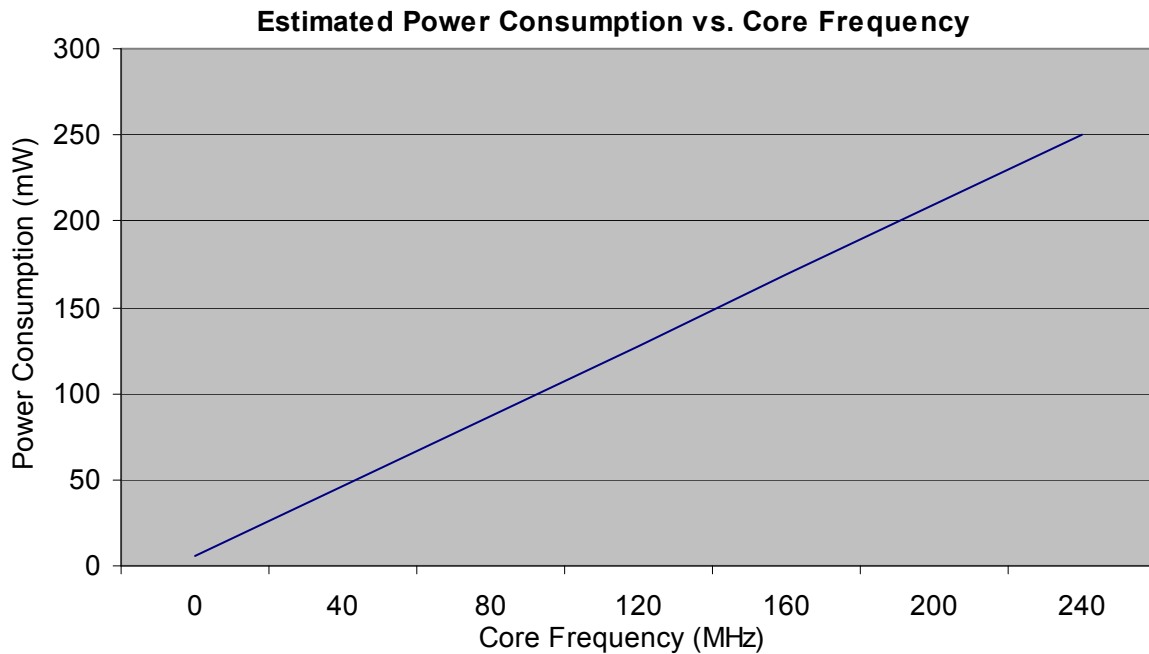

Figure 35. Estimated Maximum Power Consumption

7 Package Information

This section contains drawings showing the pinout and the packaging and mechanical characteristics of the MCF532x devices.

NOTE

The mechanical drawings are the latest revisions at the time of publication of this document. The most up-to-date mechanical drawings can be found at the product summary page located at <http://www.freescale.com/coldfire>.

7.1 Package Dimensions—256 MAPBGA

Figure 36 shows MCF5328CVM240, MCF53281CVM240, and MCF5329CVM240 package dimensions.

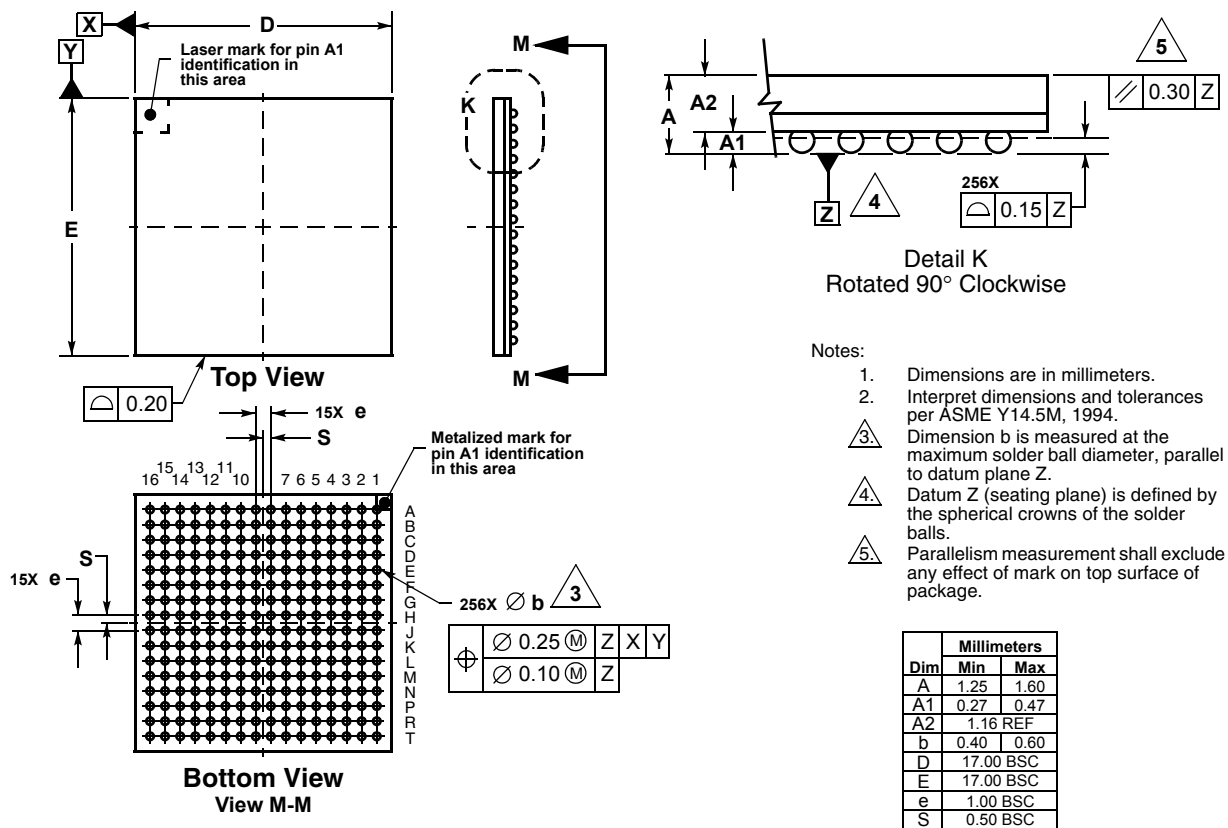

Figure 36. 256 MAPBGA Package Outline

7.2 Package Dimensions—196 MAPBGA

Figure 37 shows the MCF5327CVM240 package dimensions.

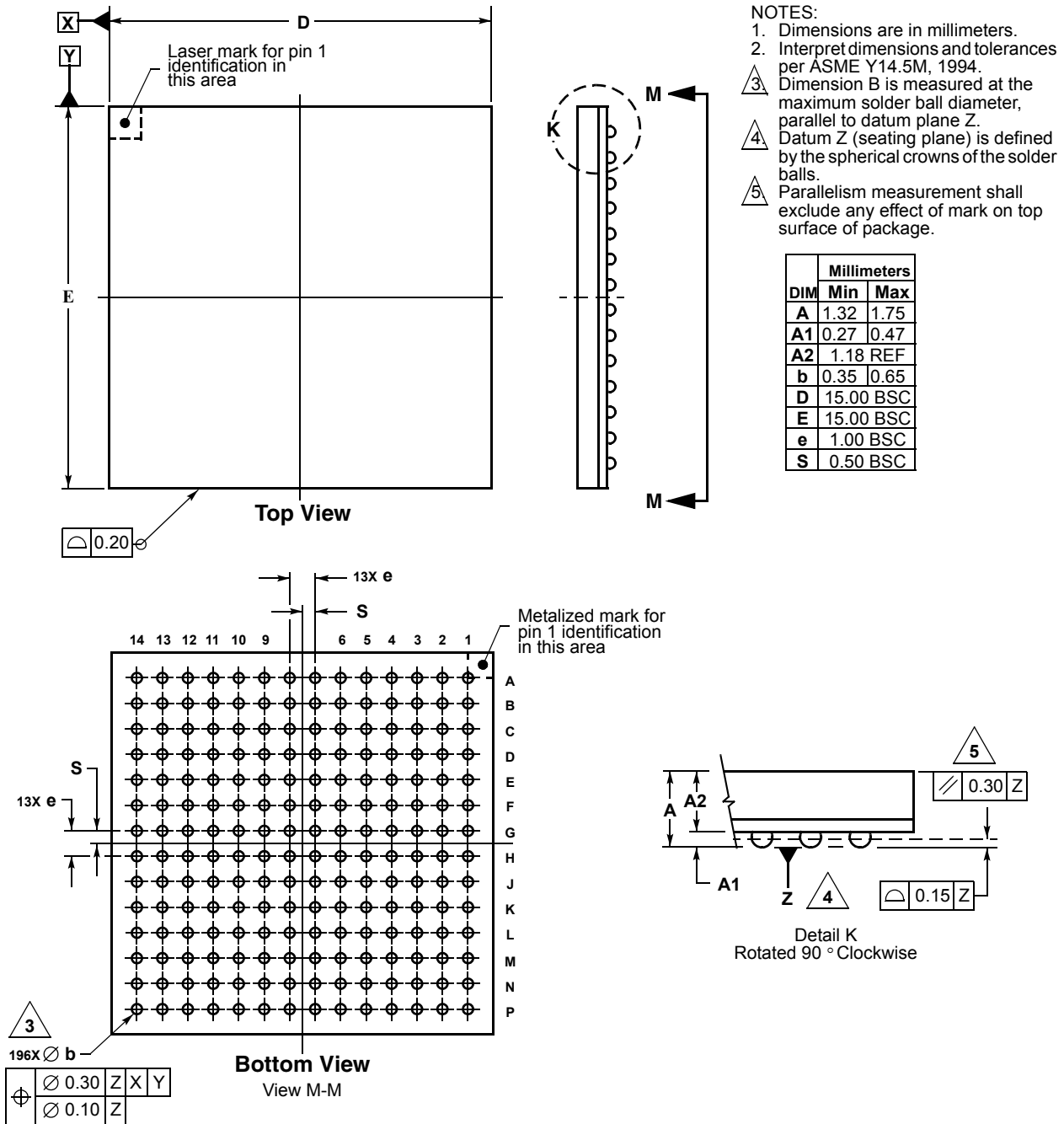

Figure 37. 196 MAPBGA Package Dimensions (Case No. 1128A-01)

8 Revision History

Table 33. MCF5329DS Document Revision History

Rev. No.	Substantive Changes	Date of Release
0	<ul style="list-style-type: none"> Initial release. 	11/2005
0.1	<ul style="list-style-type: none"> Added not to Section 7, "Package Information." Added top view and bottom view where appropriate in mechanical drawings and pinout figures. Figure 6: Corrected "FB_CLK (75MHz)" label to "FB_CLK (80MHz)" 	3/2006
1	<ul style="list-style-type: none"> Corrected MCF5327 196MAPBGA ball map locations in Table 5 for the following signals: RCON, D1, D0, OE, R/W, SD_DQS2, PSTCLK, DDATA[3:0], PST[3:0], EVDD, IVDD, and SD_VDD. Figure 5 was correct. Updated thermal characteristic values in Table 5. Updated DC electricals values in Table 7. Updated Section 3.3, "Supply Voltage Sequencing and Separation Cautions" and subsections. Updated and added Oscillator/PLL characteristics in Table 8. Table 9: Swapped min/max for FB1; Removed FB8 & FB9. Updated SDRAM write timing diagram, Figure 9. Table 11: Added values for frequency of operation and DD1. Reworded first paragraph in Section 5.12, "ULPI Timing Specification." Updated Figure 19. Replaced figure & table Section 5.13, "SSI Timing Specifications," with slave & master mode versions. Removed second sentence from Section 5.15.2, "MII Transmit Signal Timing," regarding no minimum frequency requirement for TXCLK. Removed third and fourth paragraphs from Section 5.15.2, "MII Transmit Signal Timing," as this feature is not supported on this device. Updated figure & table Section 5.19, "Debug AC Timing Specifications." Renamed & moved previous version's Section 5.5 "Power Consumption" to Section 6, "Current Consumption." Added additional real-world data to this section as well. 	7/2007
2	<ul style="list-style-type: none"> Added MCF53281 device information throughout: features list, family configuration table, ordering information table, signals description table, and relevant package diagram titles Remove Footnote 1 from Table 11. Changed document type from Advance Information to Technical Data. 	8/2007

Table 33. MCF5329DS Document Revision History (continued)

Rev. No.	Substantive Changes	Date of Release
3	<ul style="list-style-type: none"> • Corrected MCF53281 in features list table. This device contains CAN, but does not feature the cryptography accelerators. • In pin-multiplexing table, moved MCF53281 label from the MCF5328 column to the MCF5329 column, because this device contains CAN output signals. 	10/2007
4	<ul style="list-style-type: none"> • Corrected pinouts in Table 5 for 196 MAPBGA device: Changed D[15:1] entry from “F4–F1, G4–G2...” to “F4–F1, G5–G2...” Changed DSO/TDO entry from “P9” to “N9” • Corrected D0 spec in Table 30 from $1.5 \times t_{sys}$ to $2 \times t_{sys}$ for min and max values. • Updated FlexBus read and write timing diagrams in Figure 7 and Figure 8. • Removed footnote 2 from the IRQ[7:1] alternate functions USBHOST_VBUS_EN, USBHOST_VBUS_OC, SSI_MCLK, USB_CLKIN, and SSI_CLKIN signals in Table 5. • Updated pinouts for 196 MAPBGA device, MCF5327CVM240 in both Figure 5 and Table 2. The following locations are affected: G10–12, H12–14, J11–14, K12–13, L12–13, M12–14, N13. The following signals are affected: USBOTG_VDD, USBHOST_VSS, USBOTG_M, USBOTG_P, USBHOST_M, USBHOST_P, DRAMSEL, PWM3, PWM1, $\overline{IRQ}[7,4,3,2,1]$, \overline{RESET}, TDI/DSI, JTAG_EN, TMS/\overline{BKPT}. 	4/2008

THIS PAGE INTENTIONALLY BLANK

How to Reach Us:

Home Page:

www.freescale.com

Web Support:

<http://www.freescale.com/support>

USA/Europe or Locations Not Listed:

Freescale Semiconductor, Inc.
Technical Information Center, EL516
2100 East Elliot Road
Tempe, Arizona 85284
+1-800-521-6274 or +1-480-768-2130
www.freescale.com/support

Europe, Middle East, and Africa:

Freescale Halbleiter Deutschland GmbH
Technical Information Center
Schatzbogen 7
81829 Muenchen, Germany
+44 1296 380 456 (English)
+46 8 52200080 (English)
+49 89 92103 559 (German)
+33 1 69 35 48 48 (French)
www.freescale.com/support

Japan:

Freescale Semiconductor Japan Ltd.
Headquarters
ARCO Tower 15F
1-8-1, Shimo-Meguro, Meguro-ku,
Tokyo 153-0064
Japan
0120 191014 or +81 3 5437 9125
support.japan@freescale.com

Asia/Pacific:

Freescale Semiconductor Hong Kong Ltd.
Technical Information Center
2 Dai King Street
Tai Po Industrial Estate
Tai Po, N.T., Hong Kong
+800 2666 8080
support.asia@freescale.com

For Literature Requests Only:
Freescale Semiconductor Literature Distribution Center
P.O. Box 5405
Denver, Colorado 80217
1-800-441-2447 or 303-675-2140
Fax: 303-675-2150
LDCForFreescaleSemiconductor@hibbertgroup.com

Document Number: MCF5329DS

Rev. 4
04/2008

Information in this document is provided solely to enable system and software implementers to use Freescale Semiconductor products. There are no express or implied copyright licenses granted hereunder to design or fabricate any integrated circuits or integrated circuits based on the information in this document.

Freescale Semiconductor reserves the right to make changes without further notice to any products herein. Freescale Semiconductor makes no warranty, representation or guarantee regarding the suitability of its products for any particular purpose, nor does Freescale Semiconductor assume any liability arising out of the application or use of any product or circuit, and specifically disclaims any and all liability, including without limitation consequential or incidental damages. "Typical" parameters that may be provided in Freescale Semiconductor data sheets and/or specifications can and do vary in different applications and actual performance may vary over time. All operating parameters, including "Typicals", must be validated for each customer application by customer's technical experts. Freescale Semiconductor does not convey any license under its patent rights nor the rights of others. Freescale Semiconductor products are not designed, intended, or authorized for use as components in systems intended for surgical implant into the body, or other applications intended to support or sustain life, or for any other application in which the failure of the Freescale Semiconductor product could create a situation where personal injury or death may occur. Should Buyer purchase or use Freescale Semiconductor products for any such unintended or unauthorized application, Buyer shall indemnify and hold Freescale Semiconductor and its officers, employees, subsidiaries, affiliates, and distributors harmless against all claims, costs, damages, and expenses, and reasonable attorney fees arising out of, directly or indirectly, any claim of personal injury or death associated with such unintended or unauthorized use, even if such claim alleges that Freescale Semiconductor was negligent regarding the design or manufacture of the part.

RoHS-compliant and/or Pb-free versions of Freescale products have the functionality and electrical characteristics as their non-RoHS-compliant and/or non-Pb-free counterparts. For further information, see <http://www.freescale.com> or contact your Freescale sales representative.

For information on Freescale's Environmental Products program, go to <http://www.freescale.com/epp>.

Freescale™ and the Freescale logo are trademarks of Freescale Semiconductor, Inc. All other product or service names are the property of their respective owners.
© Freescale Semiconductor, Inc. 2008. All rights reserved.

